

Freightliner M2 106

Drive Axle Rear Suspensions
for Steel Leaf Spring Conversions

[®]
CLASS

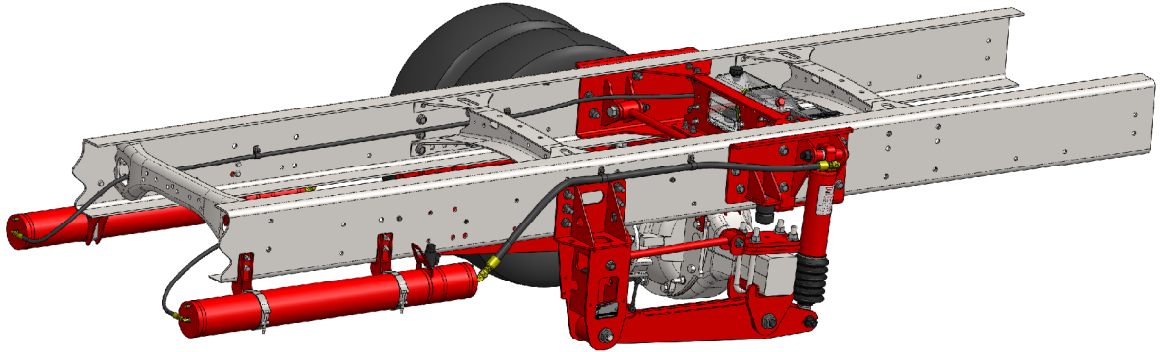

- Non-torque reactive design optimized with CLASS[®]
- Maintains proper driveline geometry through full range of torque inputs reducing driveline noise, vibration, and fatigue
- Variable stiffness and damping adjusted automatically and instantaneously based on road conditions without driver intervention
- Does not require modification to exhaust
- Compact package space claim
- 15,000 lbs GAWR
- Designed use on M2's with:
 - Hydraulic Brakes
 - OEM Steel Leaf Spring Suspension



Compressible Liquid Adaptive Suspension System

Model: DS150FR-SS

Drive Axle Rear Suspensions for Freightliner M2 106 with Steel Leaf Spring Suspension

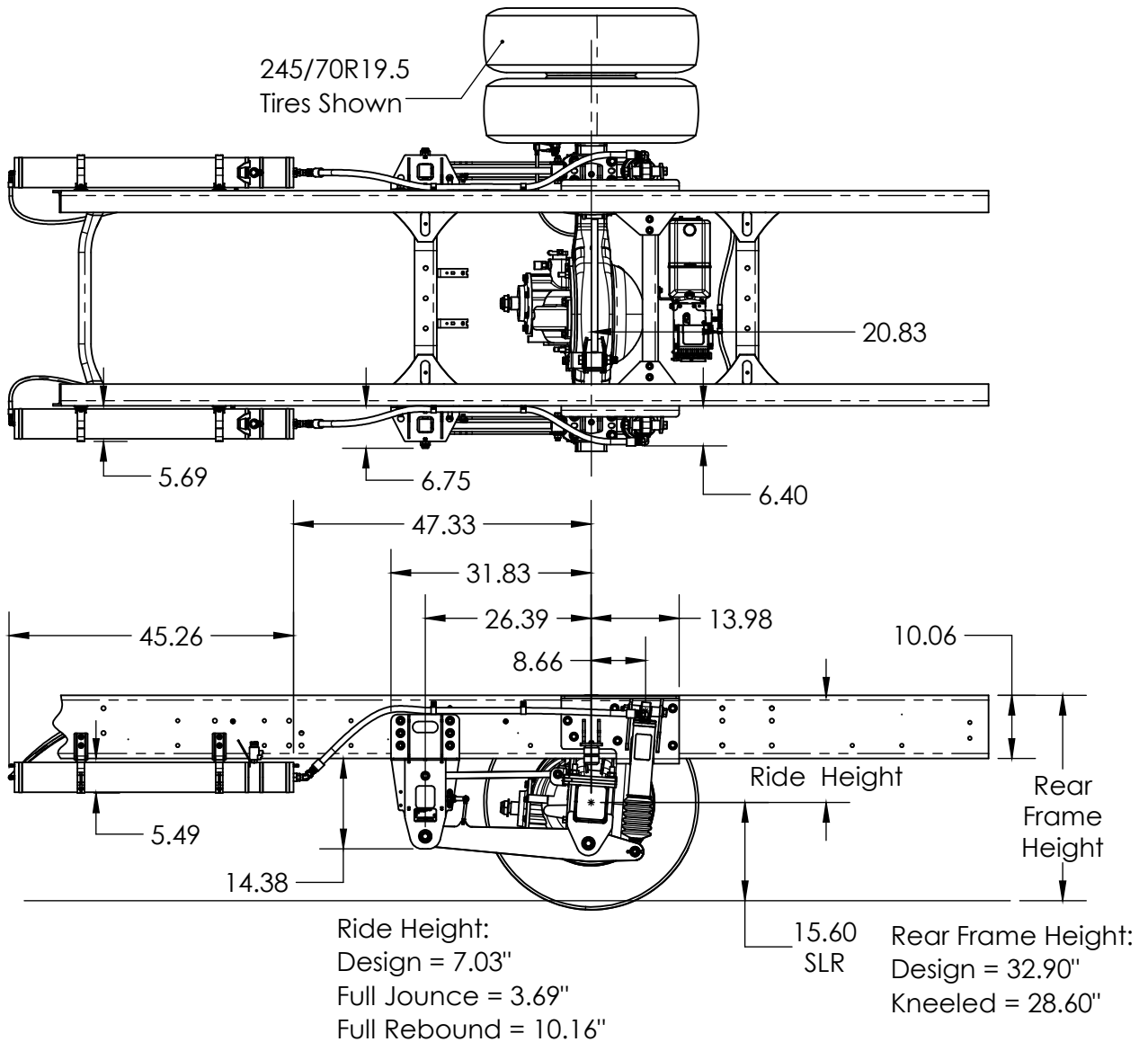

LiquidSpring™ LLC

3416 Rascal Drive
Lafayette, IN 47909

Phone: 765-474-7816

Fax: 765-474-7826

Web: www.liquidspring.com