

DS150FR

DS 150FR-A

Drive Axle Rear Suspensions
for Freightliner M2 Chassis
with Air Suspensions

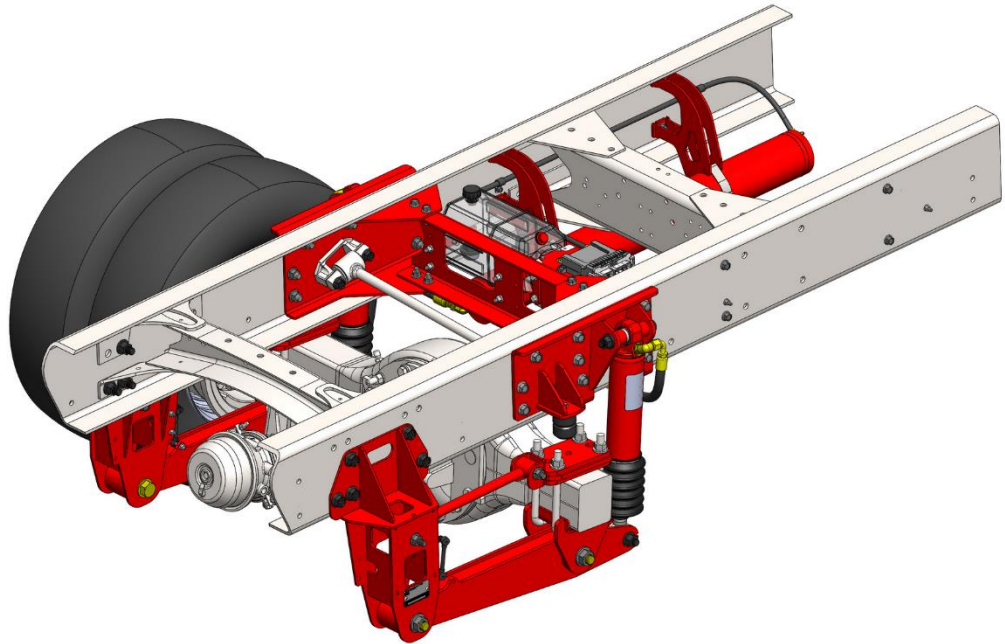

Operator Manual

D11117 Rev P 10/19

Contents

CONTENTS	2
INTRODUCTION	3
SUSPENSION APPLICATION	3
SUSPENSION RATING	3
SERIAL NUMBER TAG INFORMATION	3
VEHICLE TOWING AND JACKING INFORMATION	4
SYSTEM OPERATION	4
<i>System Start Up:</i>	4
<i>ON/OFF Button:</i>	4
<i>Warning Light:</i>	5
<i>Ride Mode Adjustment:</i>	5
<i>Ride Height Adjustment:</i>	5
<i>Depressurizing the System</i>	5
<i>Calibrating the System</i>	6
<i>Calibrating the Steering Sensor Only</i>	6
<i>Bleeding the System</i>	7
<i>Checking Fluid Level</i>	7
<i>Checking Fittings for Leaks</i>	8
SERVICE INTERVALS	8
<i>Once Daily or Before Each Shift of Usage</i>	8
<i>Initial 1,000 mile (1,600 km) Inspection</i>	8
<i>Routine Maintenance 25,000 miles (40,000 km) or 6 month maximum Interval</i>	8
MAINTENANCE RECORD	9
TROUBLESHOOTING	10
<i>Issues with Vehicle Raising/Pump</i>	10
<i>Issues with Vehicle Lowering/Dump Valve</i>	10
<i>Issues with One Corner Not Leveling Properly</i>	11
<i>Issues with Height Sensors</i>	11
<i>Issues with Ride/Handling</i>	11
<i>Issues with Steering Sensor</i>	11
<i>Issues with Vehicle Speed Signal</i>	12
<i>Issues with Vehicle Brake Signal</i>	12
<i>Issues with Door Switch</i>	12
<i>Issues with Vehicle Ignition Signal</i>	12
<i>Issues with Vehicle Park Signal</i>	12
<i>Issues with Driver Interface</i>	12
<i>Issues with Power Module</i>	13
<i>Issues with Strut Assembly</i>	13
<i>Issues with Secondary Volume Assembly</i>	14
ABBREVIATIONS	14
PART IDENTIFICATION:	15
DS150FR-A	15
DS150FR-AR	17
DS150FR-AREP	19
DS150FR-AS / -ASA	21
FRONT HANGERS	23
JOUNCE STOPS	23
AXLE CONNECTION	24
CONTROL ARMS	25
UPPER STRUT MOUNTS	26
STRUTS	27

SECONDARY VOLUMES [DS150FR-A]	28
POWER MODULE [DS150FR-A]	29
HOSE ATTACHMENT AND ROUTING [DS150FR-A]	30
SECONDARY VOLUMES (DS150FR-AR)	31
SECONDARY VOLUMES [DS150FR-AREP]	32
POWER MODULE [DS150FR-AR AND DS150FR-AREP] ..	33
HOSE ATTACHMENT AND ROUTING [DS150FR-AR AND DS150FR-AREP]	34
SECONDARY VOLUMES [DS150FR-AS / -ASA]	35
POWER MODULE [DS150FR-AS / -ASA]	36
HOSE ATTACHMENT & ROUTING [DS150FR-AS / -ASA] ..	37
HEIGHT SENSORS	38
STEERING SENSORS	39
ELECTRICAL SCHEMATICS	40

Introduction

This manual provides installation information for the LiquidSpring **CLASS**® DS150FR series of rear axle suspension systems for the Freightliner M2 106 series of chassis.

Before you begin installation of the suspension system:

1. Read and understand all instructions and procedures prior to installation of components.
2. Read and observe all Warning and Caution hazard alert messages in this publication. They provide information that can help prevent serious personal injury, damage to components, or both.
3. Follow your company's maintenance and service, installation, and diagnostics guidelines.
4. Use special tools when required to help avoid serious personal injury and damage to components.

Throughout this manual, important product information is preceded by the terms "NOTE", "IMPORTANT", "CAUTION", and "WARNING". These terms are defined as follows:

NOTE: Includes additional information to enable accurate and easy performance of procedures.

IMPORTANT: Includes additional information that if not followed could lead to hindered product performance and/or product failure.

CAUTION: A caution indicates procedures that must be followed exactly. Damage to equipment or suspension components and personal injury can occur if the procedure is not followed.

WARNING: A warning indicates procedures that must be followed exactly. Serious personal injury can occur if the procedure is not followed.

LiquidSpring LLC reserves the right to modify the suspension and/or procedures and to change specifications at any time without notice and without incurring obligation.

Suspension Application

LiquidSpring offers two (2) versions of the DS150FR line of suspensions:

Suspension	Application
DS150FR-A	Conversion of Air Spring version with under/behind cab mounted fuel tank.
DS150FR-AR	Conversion of Air Spring version with aft-of-axle mounted fuel tank and driver side exhaust routing.
DS150FR-AREP	Conversion of Air Spring version with aft-of-axle mounted fuel tank and passenger side exhaust routing.
DS150FR-AS / -ASA	Conversion of Air Suspension version.

Suspension Rating

The LiquidSpring line of DS150FR suspensions can be used on both the air brake and hydraulic brake versions of Freightliner M2 106 chassis. Suspension ratings are based on the OEM rear axle rating of each chassis:

Model	Max Suspension GAWR
DS150FR-A	15,000 lbs
DS150FR-AR	15,000 lbs
DS150FR-AREP	15,000 lbs
DS150FR-AS / -ASA	15,000 lbs

The rear axle GAWR with LiquidSpring DS150FR installed is the lesser of either the OEM original rear rating (as published) or the above suspension rating.

WARNING: Overloading suspension system may result in abnormal handling characteristics and premature wear of components.

Serial Number Tag Information

The serial number is found on an aluminum tag (Figure 1) that is riveted to the Left Hand Suspension Hanger as shown in Figure 2. This information will aid you when contacting the chassis manufacturer or LiquidSpring LLC.



Figure 1. Serial Tag

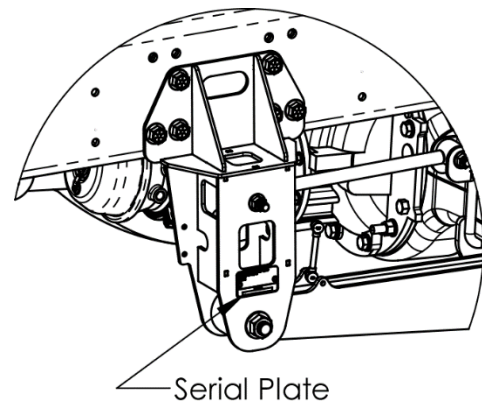

Figure 2. Serial Number Tag Location

Vehicle Towing and Jacking Information

Before attempting any type of towing procedures, the vehicle manufacturer must be referred to for the recommended towing methods.

NOTE: Before towing vehicle, check with local authorities, such as Department of Transportation, for permissible towing methods. Some states do not permit towing vehicles by chains or towing straps.

Do not attach tow apparatus (hooks, chains, straps, etc.) to the suspension components.

WARNING: Attaching towing equipment to improper locations and failure to utilize OEM/Coach Builder recommended towing methods could result in one or more of the following:

**Damage to the suspension and/or vehicle,
Loss of vehicle control,
Possible disconnect from the vehicle.**

WARNING: Do not apply jack to bottom of front hanger or other suspension components. Applying a jack to improper locations can result in damage to the suspension and/or vehicle and severe personal injury.

System Operation

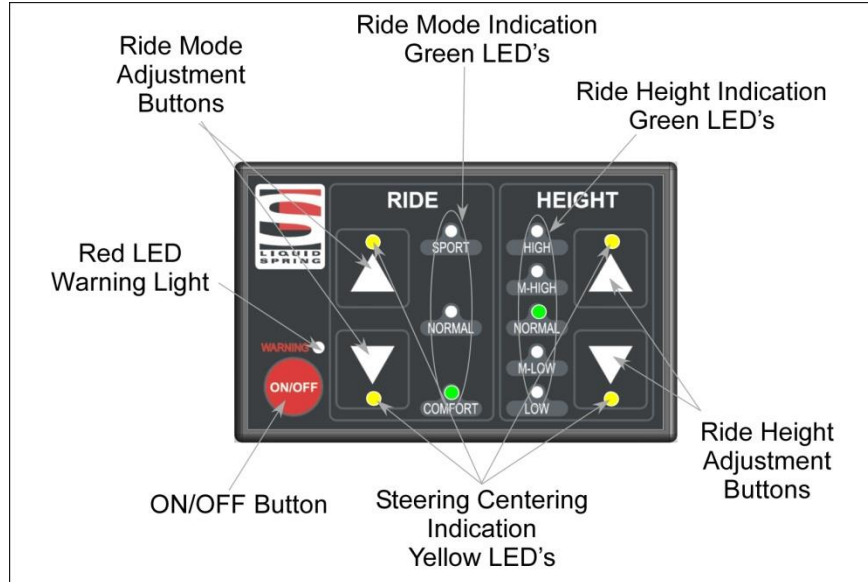

System Start Up:

- In most instances, the suspension system can be left alone to operate automatically.
- After startup, all the indicator lights will flash on for 1-2 seconds, and then the Green Ride Height Indication LED and Green Ride Mode Indication LED will light to show the current Ride Mode and Ride Height.
- The four yellow LED's will light up if the steering wheel is approximately 10°-20° each side of straight ahead, but will not light up when steering wheel exceeds 20° from center. If the vehicle is steered straight ahead and the four yellow LED's are not lit (and the red warning LED is not lit) see Calibrating the Steering Sensor Only.

- When the steering wheel is turned more than 20° off center, the four Yellow Steering Centering Indication LED will not be lit.

ON/OFF Button:

Pressing the ON/OFF button will enable/disable the suspension. When the suspension is ON, relevant LED's are lit up. When the suspension is OFF, none of the LED's are lit. It is recommended to leave the suspension ON at all times unless the vehicle or suspension is being serviced.

IMPORTANT: After turning the vehicle ignition off, the suspension system will remain powered for 1 hour before shutting off.

Warning Light:

If the Red LED warning light is continuously illuminated along with one or more of the other indicator lights, please refer to the **Troubleshooting Section** on page 10.

Ride Mode Adjustment:

Press the UP/DOWN arrow buttons to change the ride mode between SPORT, NORMAL, and COMFORT. The Green indicator light will show the set mode.

- **Comfort Mode** provides a smooth, soft ride. Use for normal city and highway driving.
- **Sport Mode** provides more “feel” or response to the road conditions. Use where road conditions or personal preference demand more control.
- **Normal Mode** is a balance between Comfort and Sport. Use where more control than Comfort is desired, but better ride than Sport.

The setting can be changed at any time. Based on road conditions, steering wheel angle, and the vehicle speed, the system automatically adjusts to provide the best handling while providing a smooth ride. All three settings will feel similar on a smooth road.

Ride Height Adjustment:

Press the UP/DOWN arrow buttons to change ride height from NORMAL to HIGH (body up) or LOW (body down).

- A solid green LED will indicate the selected height. A flashing green LED will indicate the current height and that height adjustment is occurring. When a single solid green LED is lit, the selected height has been achieved.
- Two solid green LEDs will be lit if the current height is not the selected height and height adjustment is not occurring.
- If LOW or HIGH heights are selected while the vehicle is traveling at less than 10 mph or stopped, the suspension height is either lowered or raised.
- If LOW or HIGH heights are selected while the vehicle is traveling at greater than 10 mph, the suspension will ignore the selected height and remain in NORMAL height unless the vehicle speed goes below 10 mph within 2 minutes of selecting the height. In this instance, the NORMAL height green LED will flash and the selected height green LED will be lit solid until the speed goes below 10 mph within 2 minutes of selecting the height. If the vehicle speed doesn't go below 10mph within the 2 minute period, the suspension will remain in NORMAL height indicated by only the NORMAL height green LED lit solid.

- If LOW height is selected and the ignition is turned off before LOW height is achieved, the system will continue to lower to LOW height. When LOW height is selected the system will monitor and maintain the kneeled position by only lowering as needed for 1 hour after the ignition is turned off.
- If HIGH height is selected and the ignition is turned off before HIGH height is achieved, the system will stop adjusting ride height. When HIGH height is selected the system will monitor and maintain the current position by only lowering as needed for 1 hour after the ignition is turned off.
- The door switch function (if equipped) is disabled when the driver display LOW or HIGH height is selected before the door is opened on vehicles equipped with a door switch for kneeling.

IMPORTANT: While parked for an extended time with the vehicle and/or suspension system turned off, suspension ride will change with temperature change. Increases in ambient temperature or parking in direct sunlight can cause the suspension ride height to increase. As temperature lowers, the suspension ride height can decrease.

Depressurizing the System

1. Turn the ignition key to “Run” and ensure that the LiquidSpring driver display LEDs light up and that the red “Warning” LED is not lit. If the red “Warning” LED is lit, proceed to the Trouble Shooting Section.

WARNING: Do not run vehicle in an enclosed building without adequate ventilation or without ducting exhaust fumes outside. Operation of a vehicle inside an enclosed building can lead to serious injury or death.

1. Press and release the Red ON/OFF button on the driver display. All LEDs on the driver display should go out.
2. Press and release the Red ON/OFF button again. The LEDs on the driver display should all flash and then only the four yellow arrow LEDs, one green ride mode indicator LED, and one green ride height indicator LED should remain lit.
3. Press and release the HEIGHT DOWN arrow button to lower the vehicle to the LOW height.
4. Press and hold the HEIGHT DOWN arrow button for approximately 2 minutes.
5. Release the HEIGHT DOWN arrow button.

6. Press and release the ON/OFF button to disable the system.
7. Turn off the vehicle ignition.

If any of the hydraulic connected components is to be removed and serviced, it is recommended to also follow the following steps:

8. Locate 3/16" ID PVC Tubing. Note: Alternatively, a bleed kit similar to the Actron 7840 Bleed Kit can be used.
9. Attach the PVC tubing to one of the upper bleed screws on the Left Hand Secondary Volume Assembly and place the other end in a bucket.

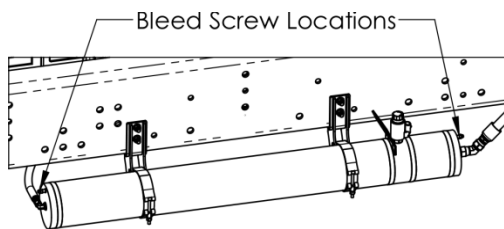

Figure 3. Bleed screw locations.

10. Open the bleed screw slightly to relieve any residual pressure.
11. After pressure is relieved, close the bleed screw and torque to 13-18 ft-lbs.

Notes:

- Jacking up the chassis of a lowered, depressurized chassis will cause a slight vacuum in the system and minimize fluid loss while disconnecting hoses.
- For service of non-hydraulic connected suspension components, the suspension system can be first raised to the HIGH height, appropriate jack stands placed under the chassis, then depressurized as listed above lowering the chassis onto the jack stands.

Calibrating the System

IMPORTANT: Proper calibration of the system must be conducted with the vehicle loaded to the as delivered condition with body installed. For calibration on an empty chassis cab, LiquidSpring recommends weight be added to the frame approximately equal to the planned body to allow for proper bushing deflections.

Note: The LiquidSpring Calibration routine will automatically determine maximum and minimum suspension ride height. Based on those ride heights, the system will determine the correct normal design ride height. The calibration system will also calibrate the steering sensor.

1. Verify that the front wheels are steered straight ahead.

2. Lower the vehicle to the ground and remove any jack stands and any other obstructions from under the vehicle.
3. To begin the calibration, turn the ignition key to "Run" and ensure that the LiquidSpring driver display lights up and that the red Error light is not blinking.

WARNING: Do not run vehicle in an enclosed building without adequate ventilation or without ducting exhaust fumes outside. Operation of a vehicle inside an enclosed building can lead to serious injury or death.

4. Press and release the Red ON/OFF button on the driver display. All lights on the driver display should go out.
5. Press and release the Red ON/OFF button a second time. The lights on the driver display should all flash then only show the four yellow arrow lights, one green ride mode indicator, and one green ride height indicator.
6. Press and hold both Ride Height Adjustment Buttons simultaneously until the SPORT, COMFORT, HIGH, and LOW green LED's begin to flash. The suspension system will begin to rise to the full high position, and then lower to the full lowered position.
7. After the system completes the calibration routine, the suspension will return to the original ride height.
8. Turn off the ignition for at least 3 minutes. Note: The suspension system will not use the calibrated ride height settings until power has been cycled.

Note: Pressing the red ON/OFF button on the driver display does not cycle power to the LiquidSpring suspension system, but only will enable/disable the system.
9. Turn the ignition back to Run, then press the Red ON/OFF button twice and verify the suspension system moves to the new and correct ride height.
10. Calibration is now completed.

Calibrating the Steering Sensor Only

Note: The yellow lights only light up when the steering sensor indicates the center location. They will not be lit outside of 10°-20° off center.

IMPORTANT: The LiquidSpring CLASS® system includes an automatic self-centering routine. In conditions such as driving on highway with significant side wind, the yellow lights may temporarily not be lit when the steering wheel is exactly centered. Rotate slowly from center to full steering stop, then repeat the opposite direction. If the yellow lights momentarily light up during the travel in one or the other direction, the system is operating normally

and the steering sensor does not need to be manually re-centered. Continue operating normally.

If the yellow lights do not light up at all during turning the steering wheel, following the instructions below.

1. Verify that the front wheels are steered straight ahead.
2. To begin the calibration, turn the ignition key to "Run" and ensure that the LiquidSpring driver display lights up and that the red "Warning" LED is not lit or flashing.

WARNING: Do not run vehicle in an enclosed building without adequate ventilation or without ducting exhaust fumes outside. Operation of a vehicle inside an enclosed building can lead to serious injury or death.

3. Press and release the Red ON/OFF button on the driver display. All LEDs on the driver display should go out.
4. Press and release the Red ON/OFF button again. The LEDs on the driver display should all flash and then only the four yellow arrow LEDs, one green ride mode indicator LED, and one green ride height indicator LED should remain lit.
5. Press and hold both Ride Height Adjustment Buttons simultaneously until the SPORT, COMFORT, HIGH, and LOW green LED's begin to flash.
6. As soon as the four green LED's begin to flash, press the ON/OFF button to stop the process.
7. Verify that the four yellow arrow LED's are lit.
8. Steering calibration is completed.

Bleeding the System

1. Verify system is turned OFF by either pressing the ON/OFF button on the driver interface until the lights are turned off or turning the ignition off.
2. Locate 3/16" ID PVC Tubing (not included with kit). Note: Alternatively, a bleed kit similar to the Actron 7840 Bleed Kit can be used.
3. Attach the PVC tubing to one of the upper bleed screws on the Left Hand Secondary Volume Assembly and place the other end in a bucket.

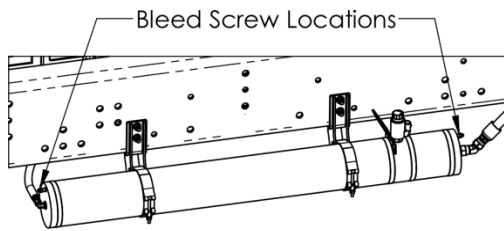

Figure 4. Bleed screw locations.

4. Open the bleed screw slightly.
5. After air bubbles are no longer present, close the bleed screw and torque to **13-18 ft-lbs.**
6. Repeat with remaining bleed screws. Note: the system may need to be powered on and allowed to re-pressurize.
7. Repeat with other side.

Checking Fluid Level

1. Turn the ignition key to "Run" and ensure that the LiquidSpring driver display LEDs light up and that the red "Warning" LED is not lit. If the red "Warning" LED is lit, proceed to the Trouble Shooting Section.

WARNING: Do not run vehicle in an enclosed building without adequate ventilation or without ducting exhaust fumes outside. Operation of a vehicle inside an enclosed building can lead to serious injury or death.

2. Press and release the Red ON/OFF button on the driver display. All LEDs on the driver display should go out.
3. Press and release the Red ON/OFF button again. The LEDs on the driver display should all flash and then only the four yellow arrow LEDs, one green ride mode indicator LED, and one green ride height indicator LED should remain lit.
4. After the suspension system stops leveling, check the fluid level in the reservoir. If low, fill to the indicated line.

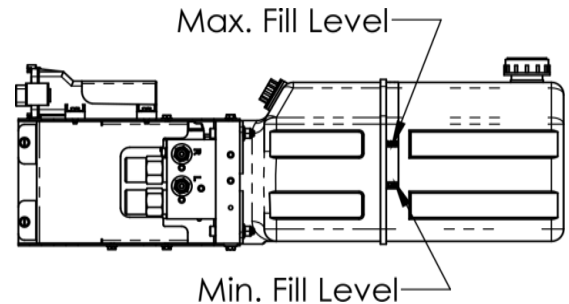

Figure 5. Final fill fluid level.

5. To add fluid, remove filler/breather cap on reservoir.
6. Locate a container of Compressible Fluid.
7. Add fluid to the reservoir until the fluid level is within the band shown in Figure 5.
8. Replace filler/breather cap and retighten.

Checking Fittings for Leaks

WARNING: The system operates under high fluid pressure (up to 3500 psi). Do not attempt to locate leaks by feeling with hands or any part of the body. High pressure fluids can penetrate the skin and cause severe tissue damage.

1. While system is at ride height and pressurized, visually examine fittings and hose connections for any source of leaks. Do not use hands to search for leak. If the source of the leak is a fitting or other component, depressurize the system and repair or replace as needed.
2. Tighten hose nuts if the leak is coming from the connection between the hose nut and a fitting.

Depressurize the system before tightening anything. Replace hose if the leak is coming from anywhere else on the hose.

WARNING: Never tighten a hydraulic fitting or hose under pressure. Always depressurize the system before adjusting fittings and hoses.

3. Clean all fluid from hose and fittings to visually identify any leaks.

IMPORTANT: Over-tightening hoses and fittings can damage components and lead to leaks.

See Installation Manual for additional instructions.

Service Intervals

Once Daily or Before Each Shift of Usage

- Check the suspension system to be sure it is fully operational.
 - After starting vehicle, verify all LED's on the driver display flash briefly, then the Green Ride Height and Ride Mode LED's are lit and the Red Warning LED does not stay on or flash.
 - Verify the four Yellow LED's are lit when the steering wheel is centered.
 - Verify that they system is at NORMAL ride height, with a steady green LED.
 - If the Driver Display indicates a blinking ride height LED, allow the system to complete leveling as indicated by a steady green LED.
 - If LOW or HIGH height is shown with a solid green LED, use the arrow buttons to raise or lower the suspension to NORMAL height.
 - Refer to **Error! Reference source not found.** Section.
- Visually inspect struts, hoses, and fittings for signs of leakage.
 - For leakage resulting in fluid pooled on the floor greater than 1" in diameter, it is recommended to service the system immediately.
 - For signs of leakage or weeping that results in wetness on components or a single drop, it is recommended to monitor the leak and schedule repair service accordingly.

Initial 1,000 mile (1,600 km) Inspection

- Inspect bolts and nuts at the control arm pivots to assure they are properly torqued.
- Inspect u-bolts to assure they are properly torqued.
- Thoroughly inspect all hydraulic connections for signs of leakage.
- Inspect reservoir fluid level.

Routine Maintenance 25,000 miles (40,000 km) or 6 month maximum Interval

- Check all suspension components for any signs of damaged/broken components, looseness, or wear.
- Inspect bolts and nuts at the control arm pivots to assure they are properly torqued.
- Inspect u-bolts to assure they are properly torqued.
- Thoroughly inspect all hydraulic connections for signs of leakage.
- Inspect reservoir fluid level.

Maintenance Record

Date of Purchase	Name and Address of Dealer	
Model of Vehicle	Vehicle Identification Number (VIN)	
Suspension Model Number		Suspension Serial Number

Date	Mileage	Service Performed

Troubleshooting

The LiquidSpring CLASS® system includes on-board diagnostics to assist in pin-pointing potential issues. When a fault in the system occurs, the red warning light on the Drivers Interface will light along with one or more of the other lights on the interface.

Driver Interface Lights	Condition	Cause	Correction
Warning + RIDE: SPORT	Battery Voltage in excess of 16VDC	Vehicle charging system providing incorrect voltage.	Inspect and replace as necessary.
		LiquidSpring system not connected to 12VDC electrical system	Inspect and replace as necessary
Warning + RIDE: NORMAL	Pump Motor runs in excess of 3 minutes	See <i>Issues with Vehicle Raising/Pump Section</i>	See <i>Issues with Vehicle Raising/Pump Section</i>
Warning + RIDE: COMFORT	Battery Voltage below 9 VDC	Vehicle charging system providing incorrect voltage	Inspect and replace as necessary
		80A fuse blown / Loss of battery voltage On circuit W25	Inspect / Repair Replace as necessary
Warning + HEIGHT: HIGH	Issue with Right Hand Height Sensor	See <i>Issues with Height Sensors Section</i>	See <i>Issues with Height Sensors Section</i>
Warning + HEIGHT: NORMAL	System kneels in excess of 3 minutes without suspension movement	See <i>Issues with Vehicle Lowering/Dump Valve Section</i>	See <i>Issues with Vehicle Lowering/Dump Valve Section</i>
Warning + HEIGHT: LOW	Issue with Left Hand Height Sensor	See <i>Issues with Height Sensors Section</i>	See <i>Issues with Height Sensors Section</i>
Slow or Fast Blinking Warning Light	Driver Interface can not communicate with ECU.	See <i>Issues with the Driver Interface.</i>	See <i>Issues with the Driver Interface. Error! Reference source not found.</i>

Issues with Vehicle Raising/Pump

Condition	Cause	Correction
Vehicle Leveled, Pump continues to run	Pump motor shorted out.	Contact LiquidSpring for further instructions.
	Software issue	Turn off ignition, wait 30 seconds, restart vehicle.
	Excessive noise in height sensor	See <i>Issues with Height Sensors</i>
Vehicle Not Leveled (or Raised), Pump runs	Reservoir fluid level low	Fill reservoir to specified level.
	Hydraulic leak in system	Check for fluid leaks and repair or replace.
	Vehicle overloaded	Check vehicle loading and correct.
	Air in pump	Check fluid level in reservoir and fill accordingly. Fully depressurize system and restart leveling.
	Internal leak in power module	Replace power module.
	Height sensor error	See <i>Issues with Height Sensors</i>
Vehicle Not Leveled (or Raised), Pump does not run	System not turned on.	Turn system on.
	Blown fuse	Check system fuses
	Loss of electrical power	Check wiring between power module and battery.
Pump runs for short time then stops	Motor controller over temperature	Contact LiquidSpring for further instructions.
Pump runs intermittently	Loose connector or wiring	Check wiring harness connections and battery connections. Repair as necessary.

Issues with Vehicle Lowering/Dump Valve

Condition	Cause	Correction
Vehicle does not lower (kneel).	System not turned on	Turn system on
	Blown fuse	Check system fuses and replace as necessary
	Obstacle under vehicle frame	Remove obstacle
	Wiring harness disconnected	Check wiring harness connections and reconnect
	Loss of electrical power	Check wiring between power module and battery
	Power module filters plugged	Contact LiquidSpring for further instructions
	Internal power module blockage	Contact LiquidSpring for further instructions
Vehicle slow lowering (kneeling)	Partial internal power module blockage	Contact LiquidSpring for further instructions

Issues with One Corner Not Leveling Properly

Condition	Cause	Correction
One side will not raise or lower	Internal power module blockage	Contact LiquidSpring for further instructions
	Low voltage	Check battery voltage.
	Wiring harness disconnected	Check wiring harness connections and reconnect
	Obstacle under vehicle frame	Remove obstacle
	Power module filters plugged	Contact LiquidSpring for further instructions
One corner raises and lowers slower than other corners	Height sensor error	See <i>Issues with Height Sensors</i>
	Internal power module blockage	Contact LiquidSpring for further instructions
	Filter partially clogged	Contact LiquidSpring for further instructions

Issues with Height Sensors

Condition	Cause	Correction
Vehicle or corner stops leveling at incorrect height	Damaged height sensor and/or linkage	Inspect height sensor components. Replace as necessary.
	Incorrect calibration	Recalibrate vehicle – see System Operation section.
	Incorrect height sensor installation	Inspect height sensor components and correct.
Corner height where leveling stops is inconsistent	Sensor or Linkage loose	Inspect installation of height sensor and linkages and tighten if necessary
	Loose connector / wire	Inspect wiring between sensor and power module for loose connection
Vehicle will not level - no height sensor signal	Height Sensor wiring shorted, broken, or disconnected	Inspect wiring between sensor and power module.
	Malfunction in Sensor	Replace sensor.
No Height Sensor Signal change while driving	Linkage broken/disconnected	Inspect installation of height sensor and linkages. Correct and/or replace.

Issues with Ride/Handling

Condition	Cause	Correction
Vehicle rolls side to side excessively	System inactive (Drivers interface dark)	Turn system on (press On/Off button)
	No electrical power to system	Inspect and replace as necessary
	Strut bushings worn	Inspect and replace as necessary
	Control arm bushings worn	Inspect and replace as necessary
	Sway bar bushings worn	Inspect and replace as necessary
	Strut mounting loose	Inspect and replace as necessary
	Rate Valve wiring shorted, broken, or disconnected	Inspect wiring and correct/replace as necessary.
	Voltage to Rate Valve solenoid too low	Check battery voltage.
	Rate Valve Poppet Jammed open	Contact LiquidSpring for further instructions
Excessive stiffness when on flat, straight road	No vehicle speed signal	See <i>Issues with Vehicle Speed Signal</i> section.
	Short to Rate Valve	Check wiring between rate valve (on secondary volume) and power module for signs of shorts. Replace as necessary.
	Wiring to Rate Valve incorrect	Inspect wiring and correct as necessary

Issues with Steering Sensor

Condition	Cause	Correction
No steering signal (reduced roll control when cornering)	Steering sensor wiring broke or incorrect.	Inspect wiring to steering sensor and correct as necessary.
	Steering sensor malfunction	Replace sensor
	Steering sensor not installed correctly	Inspect installation and correct as necessary
Yellow lights on driver display not lit when steered straight ahead.	Zero point of steering sensor incorrect.	See <i>Calibrating the Steering Sensor Only</i> .
Intermittent steering sensor signal	Loose connector / wire	Check wiring between Steering sensor and Power module for loose connection.

Issues with Vehicle Speed Signal

Condition	Cause	Correction
System leveling excessively while driving.	Speed Sensor wiring shorted, broken, or disconnected	Inspect wiring and repair/replace as necessary
	Speed signal malfunction	Replace OEM speed sensor. See OEM service manual.
Intermittent speed sensor signal	Loose connector / wire	Check wiring between Speed sensor and Power module for loose connection.

Issues with Vehicle Brake Signal

Condition	Cause	Correction
Vehicle will not level	Brake signal wire not correctly tapped.	Inspect wiring and repair/replace as necessary.
	Brake switch malfunction	Replace OEM speed sensor. See OEM service manual.
Intermittent leveling	Loose connector / wire	Inspect wiring and repair/replace as necessary.

Issues with Door Switch

Condition	Cause	Correction
Vehicle will not kneel when rear door opened	Short or break in wiring between door switch and power module.	Inspect wiring and repair/replace as necessary.
	Door switch malfunction	Inspect door switch and repair/replace as necessary
Vehicle kneels whenever speed below 5mph	Short or break in wiring between door switch and power module.	Inspect wiring and repair/replace as necessary.
	Door Switch out of adjustment	Check installation of door switch and adjust as necessary
	Door switch malfunction	Inspect and replace per body builder instructions.
Intermittent door switch signal	Loose connector / wire	Inspect wiring and repair/replace as necessary.

Issues with Vehicle Ignition Signal

Condition	Cause	Correction
System does not turn on (no leveling or stiffness control)	No ignition signal to controller or driver interface	Inspect wiring and repair/replace as necessary.
	Ignition "sensor" malfunction	Inspect and replace per OEM service manual.
System does not turn off once ignition switched off	Signal side short to battery	Inspect wiring and repair/replace as necessary.
	Ignition "sensor" malfunction	Inspect and replace per OEM service manual.
System intermittently works	Loose connector / wire	Inspect wiring and repair/replace as necessary.

Issues with Vehicle Park Signal

Condition	Cause	Correction
System will start up but won't level when parked	No park signal to controller	Inspect wiring and repair/replace as necessary.
	Park sensor malfunction	Inspect and replace per OEM service manual.
System levels when stopped and not in park	Park signal always on	Inspect wiring and repair/replace as necessary.
	Park sensor malfunction	Inspect and replace per OEM service manual.
Intermittent leveling when stopped in or out of park	Loose connector / wire	Inspect wiring and repair/replace as necessary.

Issues with Driver Interface

Condition	Cause	Correction
Warning light blinks, system appears to level.	CAN wires crossed or not connected.	Inspect wiring and repair/replace as necessary.
	Malfunctioning Driver Interface	Inspect and replace as necessary.
Warning light blinks, system does not appear to operate (level)	No power to ECU (5A 18ga Red Wire)	Inspect wiring and repair/replace as necessary.
	No ignition signal to ECU (Yellow Wire)	Inspect wiring and repair/replace as necessary.
	CAN wires crossed or not connected.	Inspect wiring and repair/replace as necessary.

Issues with Power Module

Condition	Cause	Correction
Pump exhibits high pitch whine immediately after pump stops or when vehicle lowering	The Check Valve is stuck open	Replace Power Module
Pump running under heavy load and leveling slow	The Check Valve is only partially open	Replace Power Module
Pump running under heavy load and no leveling	The Check valve is stuck closed	Replace Power Module
Hydraulic fluid leaking from Power Module	O-ring failure	Replace O-ring
	Manifold cracked	Replace Power Module
	Fitting loose	Tighten fittings
	Valve loose	Tighten valves to correct torque
	Bolts between manifolds loose/broken	Replace and /or tighten bolts to correct torque
	Hydraulic line loose	Tighten hydraulic line correctly
	Bolts between reservoir and manifold loose/broken	Replace and/or tighten bolts to required torque
	Broken / cracked reservoir	Replace reservoir

Issues with Strut Assembly

Condition	Cause	Correction
Hydraulic Leak	Weld failure between cylinder and end	Replace strut
	Cylinder fracture	Replace strut
	Threads stripped between cylinder and gland	Replace strut
	Seals worn out	Replace strut
	Rod severely scratched or dented	Replace strut
	Fitting loose	Tighten or replace fittings
	Hose failure	Replace failed hose
	Hose cut	Replace failed hose
Rod broken at bushing housing	Weld failure	Replace strut
Rod doesn't move freely in/out cylinder	Piston jammed in cylinder	Replace strut
Rod moves very easily in/out cylinder	Piston broken therefore no damping	Replace strut
Reduced damping level	Damping components broken/worn out	Replace strut
Strut upper mount not securely attached to frame or Strut	Bolts attaching bracket to frame broken / came out	Replace bolts and tighten to required torque
	Bolt attaching strut to bracket broke / came out	Replace bolts and tighten to required torque
	Weld Failure	Replace strut upper mount
	Structural failure	Replace strut upper mount
Strut lower mount not securely attached to axle or strut	Bolts attaching bracket to axle broken / came out	Replace bolts and tighten to required torque
	Bolt attaching strut to bracket broke / came out	Replace bolts and tighten to required torque
	Weld Failure	Replace strut lower mount
	Structural failure	Replace strut lower mount

Issues with Secondary Volume Assembly

Condition	Cause	Correction
Hydraulic Leak	Weld failure between tube and end	Replace secondary volume welded assembly
	Weld failure between tube and manifold	Replace secondary volume welded assembly
	Cylinder fracture	Replace secondary volume welded assembly
	Bleed screw loose	Tighten bleed screws to appropriate torque
	Fitting loose	Tighten all fittings
	Hose failure	Replace failed hose
loose or no longer attached	Hose cut	Replace failed hose
	Bolts attaching bracket to frame broken / came out	Replace bolts and tighten to required torque
	Bolt attaching volumes to bracket broke / came out	Replace bolts and tighten to required torque
	Weld Failure	Replace brackets
	Structural failure	Replace brackets

Abbreviations

The following abbreviations will be used throughout the manual.

HCS Hex Cap Screw

HFB Hex Flange Bolt

SHCS Socket Head Cap Screw

SFHS Serrated Flange Hex Screw

STS Self Tapping Screw

HN Hex Nut, Non-locking

LHN Locking Hex Nut

LFN Locking Flange Nut

CHN Castle Hex Nut

HTCN Hex Thin Castle Nut

HFW Hardened Flat Washer

SLW Spring Lock Washer

FW Flat Washer

SAE SAE O-Ring Fitting

37° SAE or JIC 37° Flare Fitting (F – Female)

LH Left Handed Part

RH Right Handed Part

UCA Upper Control Arm

LCA Lower Control Arm

Part Identification:
DS150FR-A

Note: Portion of Item (30) removed for clarity.

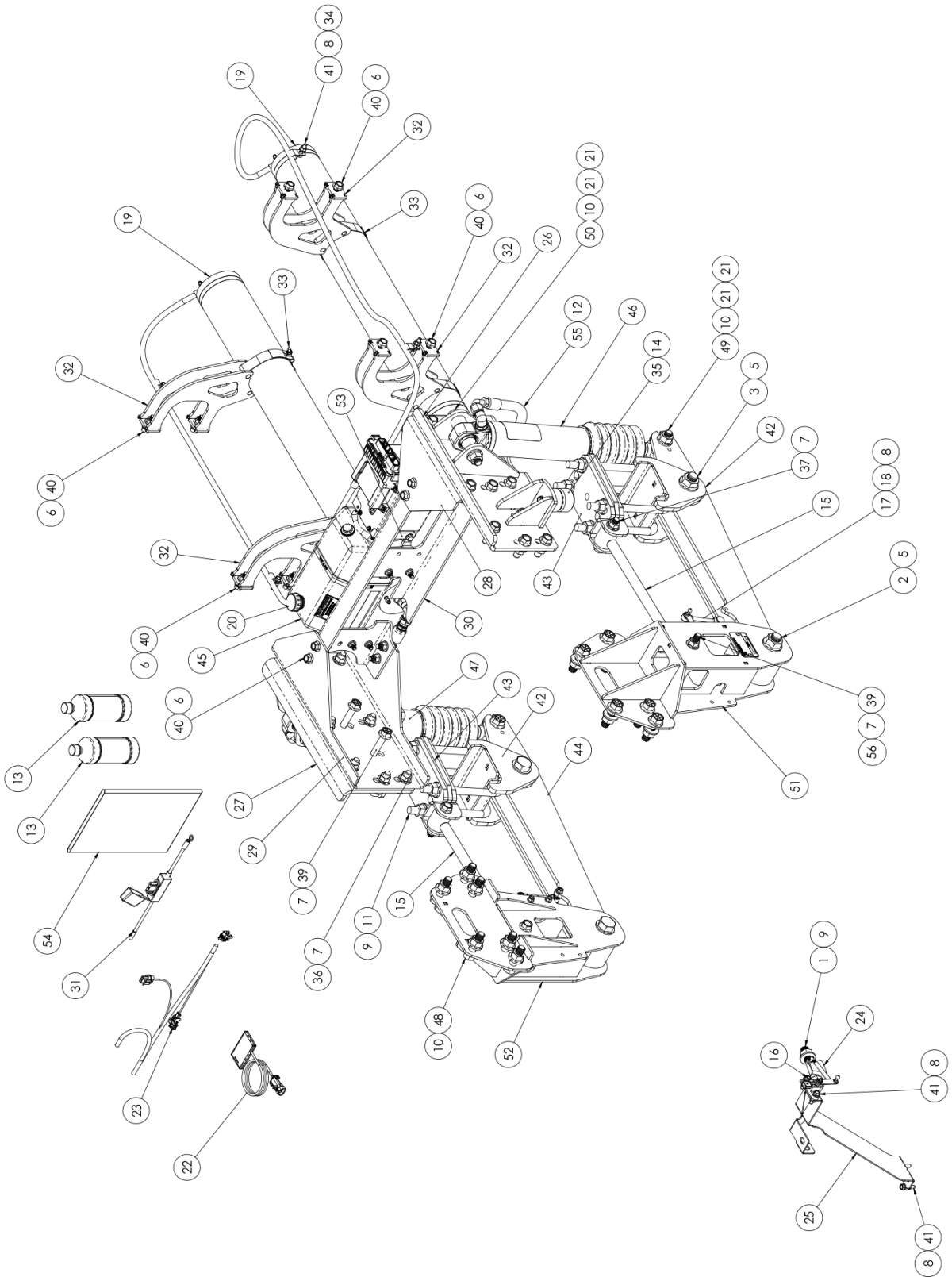

DS150FR-A

ITEM	QTY	PART NUMBER	DESCRIPTION	ITEM	QTY	PART NUMBER	DESCRIPTION
1	1	10001-005	HCS 3/4-16 x 4-1/2 Gr 8	29	1	10795-009	Mount, Crossmember, RH
2	2	10003-003	HB 1.000-8x6.000, Gr. 8	30	1	10796-007	Crossmember Channel
3	2	10003-004	HB 1.000-8x6.500, Gr. 8	31	1	10815-001	Fused Battery Lead
4	4	10006-004	HFW 1.000	32	4	10830-017	Volume Mount
5	4	10012-003	LFN 1-8, Gr G, Z Top Lock	33	4	10843-003	T-Bolt Clamp, Range 4.88-5.5
6	16	10012-007	LFN 1/2-13, Gr. G	34	4	10855-003	Vinyl-Coated Loop Clamp, 5/8" ID
7	22	10012-008	LFN 5/8-11 Gr G	35	2	10867-003	Jounce Bumper, 2.375"Dia x 3.00"T
8	14	10012-010	LFN 5/16-18, Gr. G	36	16	10874-200	HFB 5/8-11x2.000, Gr. 8
9	9	10012-012	LFN 3/4-16, Gr. G	37	2	10874-375	HFB 5/8-11x3.750, Gr. 8
10	16	10012-014	LFN 3/4-10 Gr G	38	2	10874-500	HFB 5/8-11x5", Gr. 8
11	4	10064-005	U-Bolt 3/4-16 x 9.03 Tri-8	39	2	10874-600	HFB 5/8-11 x 6", Gr. 8
12	2	10322-010	Hyd Fit 90, -10 37 x -10 37 F	40	16	10885-150	HFB 1/2-13x1.500, Gr. 8
13	2	10474-001	Silicone Oil, 16 oz. Bottle	41	12	10886-125	HFB 5/16-18 x 1.25, Gr. 8
14	2	10502-001	HFB M10-1.5 x 30 CL 10.9	42	2	10947-005	Lower Axle Clamp
15	2	10570-005	UCA (17.896)	43	2	10949-003	Upper Axle Clamp
16	3	10586-001	Sensor	44	2	10953-004	Lower Control Arm
17	3	10587-006	Linkage, 3.938" SS	45	1	11013-004	Asy, Power Supply, Side Mount
18	2	10591-003	Ball Stud 5/16-18 x .75L	46	1	11057-003	Asy, Strut
19	2	10597-047	2nd Vol 50 x 450, LH	47	1	11057-004	Asy, Strut
20	1	10614-001	Cap, Filler/Breather	48	12	11102-250	HFB 3/4-10 x 2-1/2 Gr 8
21	8	10640-005	Bearing Spacer, 1.24 x .812 x .318	49	2	11102-400	HFB 3/4-10 x 4 Gr 8
22	1	10680-001	Driver Interface	50	2	11102-650	HFB 3/4-10 x 6-1/2 Gr 8
23	1	10704-009	Wiring Harness, Dash, M2	51	1	11104-001	LH Front Hanger
24	1	10733-004	Steering Linkage Mnt	52	1	11105-001	RH Front Hanger
25	1	10741-005	Steering Sensor Mnt	53	1	11109	Kit, Power Module Mounting
26	1	10790-012	Upper Strut Mount, LH	54	1	11113	Kit, Drawing, Freightliner M2
27	1	10790-013	Upper Strut Mount, RH	55	2	11458-019	Asy, Hose -10 x 19" L
28	1	10795-008	Mount, Crossmember, LH	56	4	11689-001	Spacer, Plastic, M2

DS150FR-AR

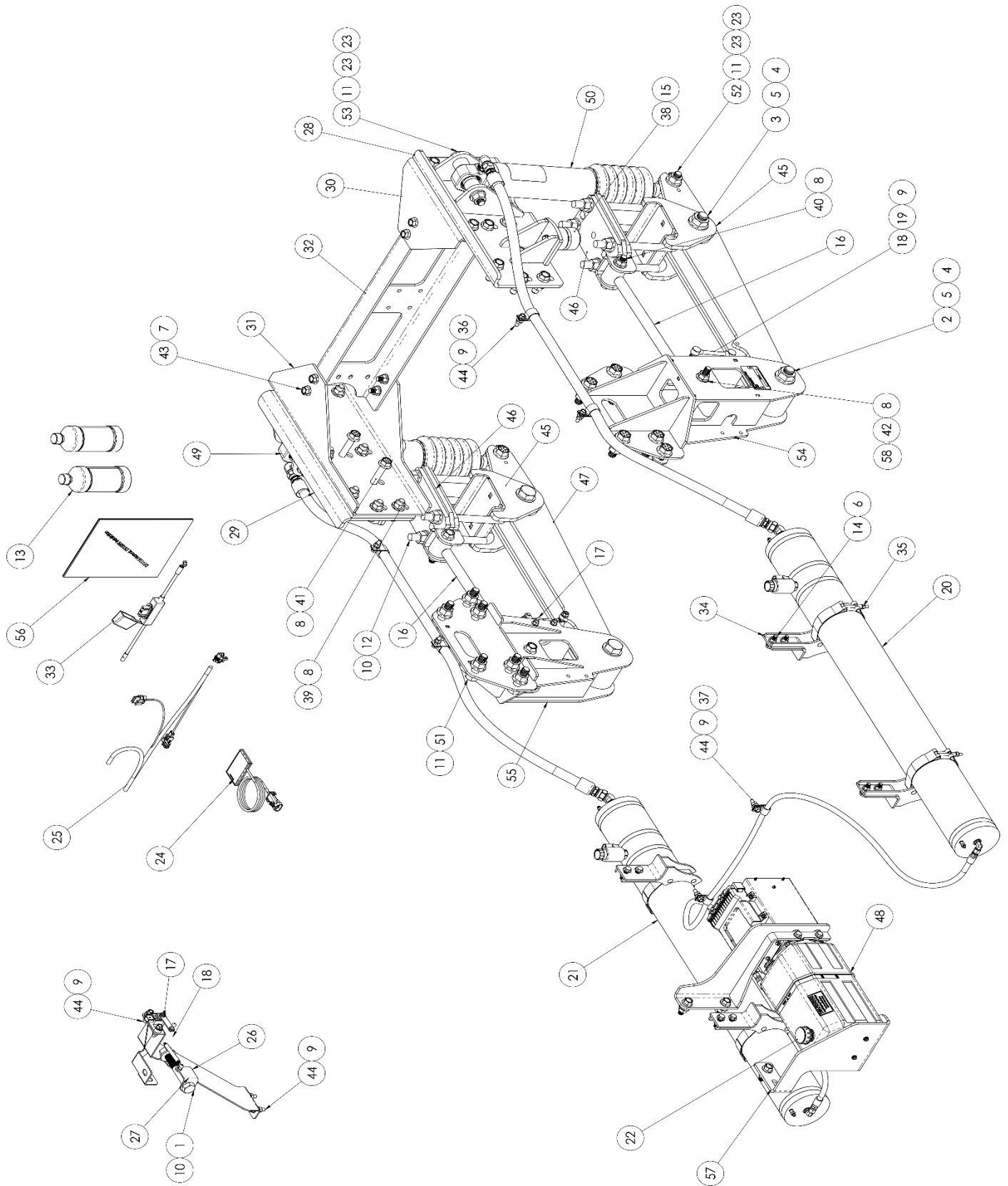

DS150FR-AR

ITEM	QTY	PART NUMBER	DESCRIPTION	ITEM	QTY	PART NUMBER	DESCRIPTION
1	1	10001-005	HCS 3/4-16 x 4-1/2 Gr 8	30	1	10795-008	Mount, Crossmember, LH
2	2	10003-003	HB 1.000-8x6.000, Gr. 8	31	1	10795-009	Mount, Crossmember, RH
3	2	10003-004	HB 1.000-8x6.500, Gr. 8	32	1	10796-007	Crossmember Channel
4	4	10006-004	HFW 1.000	33	1	10815-001	Wiring Harness, Fused Battery Lead
5	4	10012-003	LFN 1-8, Gr G Top Lock	34	4	10830-015	Volume mount, Bolt-on
6	8	10012-005	LFN 3/8-16 Gr G	35	4	10843-003	T-Bolt Clamp, Range 4.88-5.5
7	8	10012-007	LFN 1/2-13, Gr. G	36	4	10855-002	Vinyl-Coated Loop Clamp, 1" ID
8	22	10012-008	LFN 5/8-11 Gr G	37	2	10855-003	Vinyl-Coated Loop Clamp, 5/8" ID
9	16	10012-010	LFN 5/16-18, Gr. G	38	2	10867-003	Jounce Bumper, 2.375" Dia x 3.00"T
10	9	10012-012	LFN 3/4-16, Gr. G	39	16	10874-200	HFB 5/8-11x2.000, Gr. 8
11	16	10012-014	LFN 3/4-10 Gr G	40	2	10874-375	HFB 5/8-11x3.750, Gr. 8
12	4	10064-005	U-Bolt 3/4-16 x 9.03 Tri-8	41	2	10874-500	HFB 5/8-11x5.000, Gr. 8
13	1	10474-001	Silicone Oil, 16 oz. Bottle	42	2	10874-600	HFB 5/8-11 x 6", Gr. 8
14	8	10501-002	HFB 3/8-16 x 1.250 Gr 8	43	8	10885-150	HFB 1/2-13x1.500, Gr. 8
15	2	10502-001	HFB M10-1.5 x 30 CL 10.9	44	14	10886-125	HFB 5/16-18 x 1.25, Gr. 8
16	2	10570-005	UCA (17.896)	45	2	10947-005	Lower Axle Clamp
17	3	10586-001	Sensor	46	2	10949-003	Upper Axle Clamp
18	3	10587-006	Linkage, 3.938" SS	47	2	10953-004	Lower Control Arm
19	2	10591-003	Ball Stud 5/16-18 x .75L	48	1	11013-004	Power Supply, Side Mount
20	1	10597-051	2nd Vol 50 x 450, LH	49	1	11057-003	Strut
21	1	10597-052	2nd Vol 50 x 450, RH	50	1	11057-004	Strut
22	1	10614-001	Cap, Filler/Breather	51	12	11102-250	HFB 3/4-10 x 2-1/2 Gr 8
23	8	10640-005	Bearing Spacer, 1.24 x .812 x .318	52	2	11102-400	HFB 3/4-10 x 4 Gr 8
24	1	10680-001	Driver Interface	53	2	11102-650	HFB 3/4-10 x 6-1/2 Gr 8
25	1	10704-009	Wiring Harness, Dash, M2	54	1	11104-001	LH Front Hanger
26	1	10733-004	Steering Linkage Mnt	55	1	11105-001	RH Front Hanger
27	1	10741-005	Steering Sensor Mnt	56	1	11113	Kit, Drawing, Freightliner M2
28	1	10790-012	Upper Strut Mount, LH	57	1	11129	Kit, Power Module Mounting
29	1	10790-013	Upper Strut Mount, RH	58	4	11689-001	Spacer, Plastic, M2

DS150FR-AREP

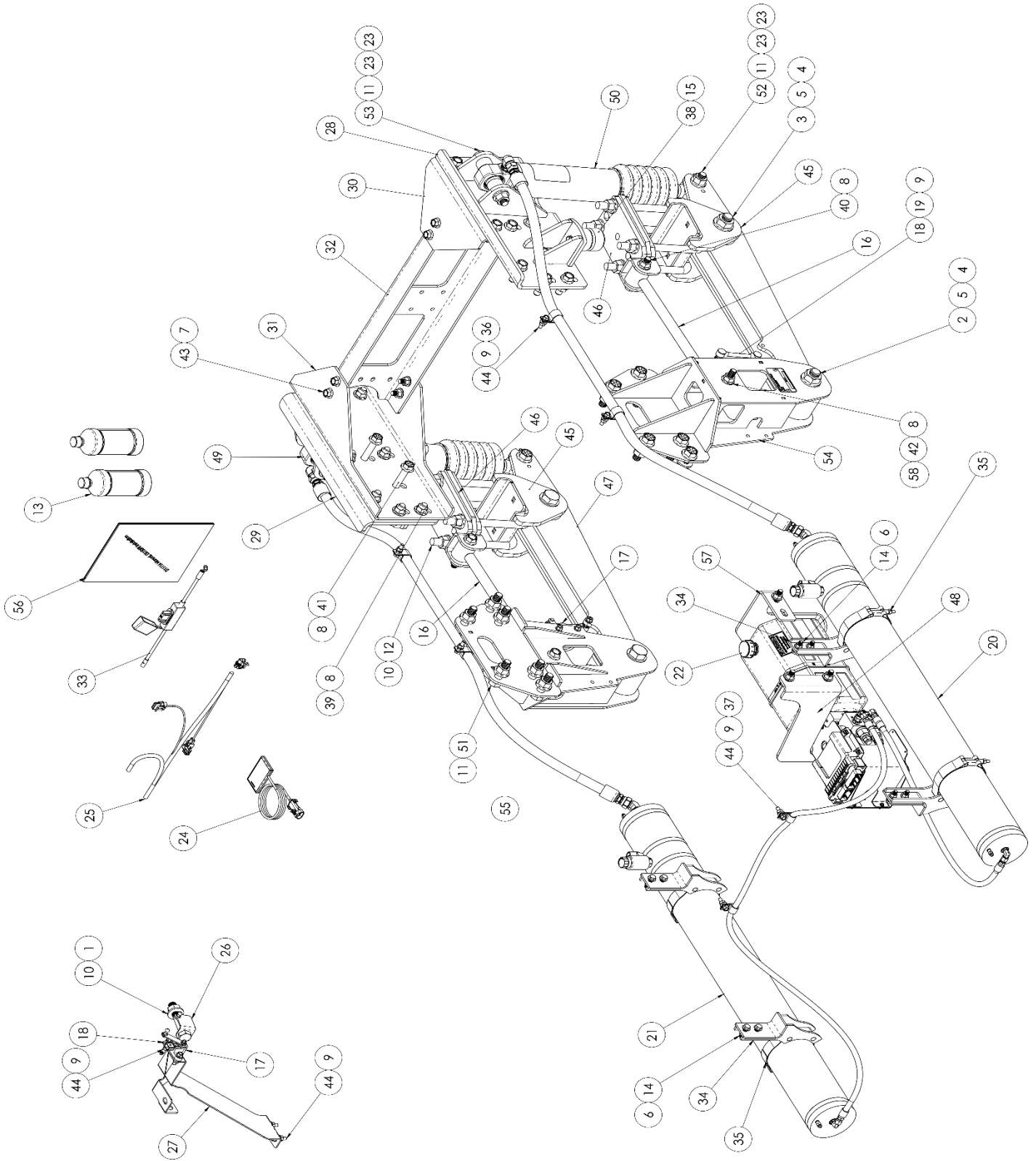

DS150FR-AREP

ITEM	QTY	PART NUMBER	DESCRIPTION	ITEM	QTY	PART NUMBER	DESCRIPTION
1	1	10001-005	HCS 3/4-16 x 4-1/2 Gr 8	30	1	10795-008	Mount, Crossmember, LH
2	2	10003-003	HB 1.000-8x6.000, Gr. 8	31	1	10795-009	Mount, Crossmember, RH
3	2	10003-004	HB 1.000-8x6.500, Gr. 8	32	1	10796-007	Crossmember Channel
4	4	10006-004	HFW 1.000	33	1	10815-001	Wiring Harness, Fused Battery Lead
5	4	10012-003	LFN 1-8, Gr G Top Lock	34	4	10830-015	Volume mount, Bolt-on
6	8	10012-005	LFN 3/8-16 Gr G	35	4	10843-003	T-Bolt Clamp, Range 4.88-5.5
7	8	10012-007	LFN 1/2-13, Gr. G	36	4	10855-002	Vinyl-Coated Loop Clamp, 1" ID
8	22	10012-008	LFN 5/8-11 Gr G	37	2	10855-003	Vinyl-Coated Loop Clamp, 5/8" ID
9	16	10012-010	LFN 5/16-18, Gr. G	38	2	10867-003	Jounce Bumper, 2.375" Dia x 3.00"T
10	9	10012-012	LFN 3/4-16, Gr. G	39	16	10874-200	HFB 5/8-11x2.000, Gr. 8
11	16	10012-014	LFN 3/4-10 Gr G	40	2	10874-375	HFB 5/8-11x3.750, Gr. 8
12	4	10064-005	U-Bolt 3/4-16 x 9.03 Tri-8	41	2	10874-500	HFB 5/8-11x5.000, Gr. 8
13	1	10474-001	Silicone Oil, 16 oz. Bottle	42	2	10874-600	HFB 5/8-11 x 6", Gr. 8
14	8	10501-002	HFB 3/8-16 x 1.250 Gr 8	43	8	10885-150	HFB 1/2-13x1.500, Gr. 8
15	2	10502-001	HFB M10-1.5 x 30 CL 10.9	44	14	10886-125	HFB 5/16-18 x 1.25, Gr. 8
16	2	10570-005	UCA (17.896)	45	2	10947-005	Lower Axle Clamp
17	3	10586-001	Sensor	46	2	10949-003	Upper Axle Clamp
18	3	10587-006	Linkage, 3.938" SS	47	2	10953-004	Lower Control Arm
19	2	10591-003	Ball Stud 5/16-18 x .75L	48	1	11013-004	Power Supply, Side Mount
20	1	10597-055	2nd Vol 50 x 450, LH	49	1	11057-003	Strut
21	1	10597-056	2nd Vol 50 x 450, RH	50	1	11057-004	Strut
22	1	10614-001	Cap, Filler/Breather	51	12	11102-250	HFB 3/4-10 x 2-1/2 Gr 8
23	8	10640-005	Bearing Spacer, 1.24 x .812 x .318	52	2	11102-400	HFB 3/4-10 x 4 Gr 8
24	1	10680-001	Driver Interface	53	2	11102-650	HFB 3/4-10 x 6-1/2 Gr 8
25	1	10704-009	Wiring Harness, Dash, M2	54	1	11104-001	LH Front Hanger
26	1	10733-004	Steering Linkage Mnt	55	1	11105-001	RH Front Hanger
27	1	10741-005	Steering Sensor Mnt	56	1	11113	Kit, Drawing, Freightliner M2
28	1	10790-012	Upper Strut Mount, LH	57	1	11129	Kit, Power Module Mounting
29	1	10790-013	Upper Strut Mount, RH	58	4	11689-001	Spacer, Plastic, M2

DS150FR-AS / -ASA

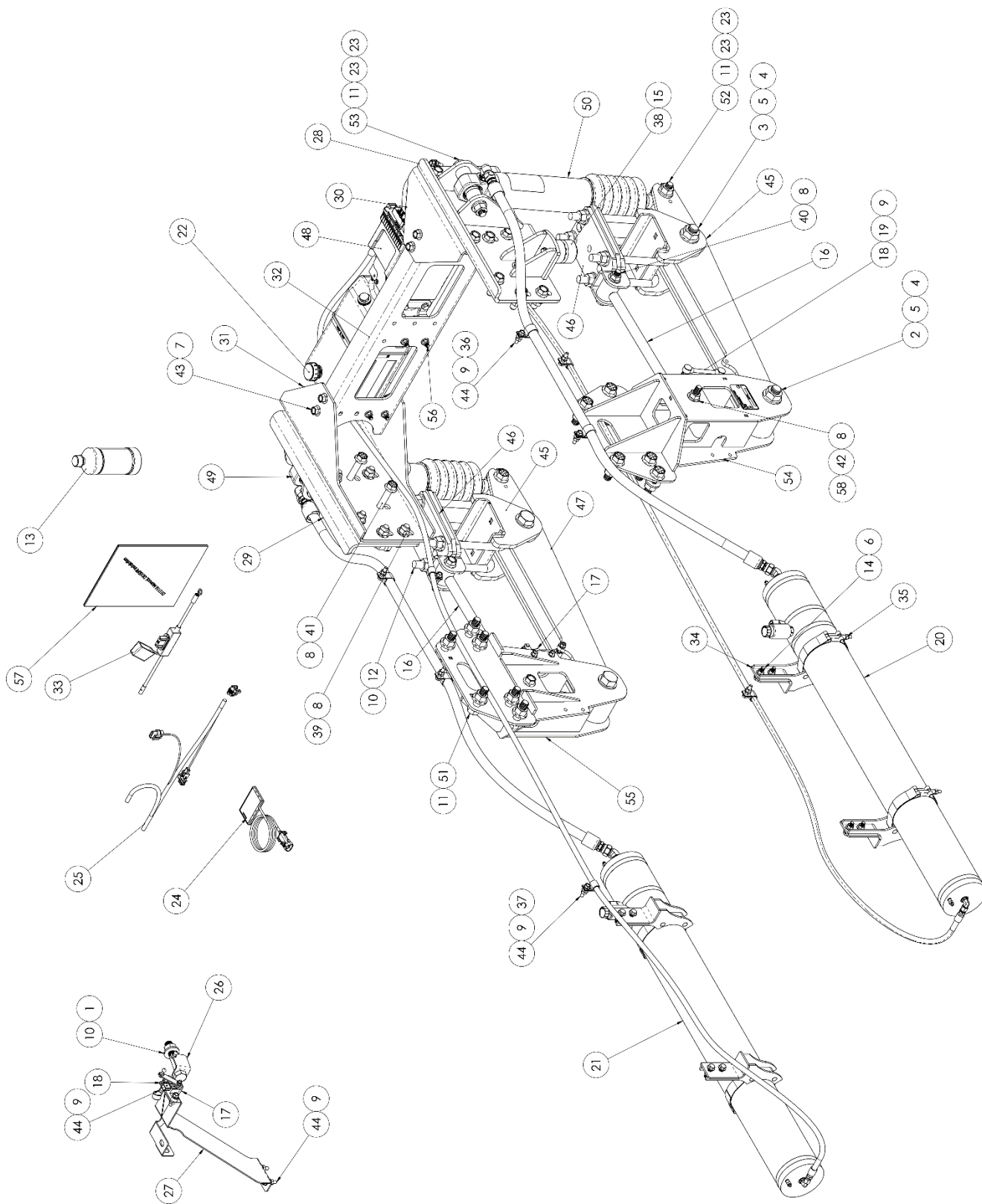

DS150FR-AS

ITEM	QTY	PART NUMBER	DESCRIPTION	ITEM	QTY	PART NUMBER	DESCRIPTION
1	1	10001-005	HCS 3/4-16 x 4-1/2 Gr 8	31	1	10795-009	Mount, Crossmember, RH
2	2	10003-003	HB 1.000-8x6.000, Gr. 8	32	1	10796-007	Crossmember Channel
3	2	10003-004	HB 1.000-8x6.500, Gr. 8	33	1	10815-001	Fused Battery Lead
4	4	10006-004	HFW 1.000	34	4	10830-015	Volume mount, Bolt-on (-AS)
5	4	10012-003	LFN 1-8, Gr G Top Lock			10830-013	Volume mount, Bolt-on (-ASA)
6	8	10012-005	LFN 3/8-16 Gr G	35	4	10843-003	T-Bolt Clamp, Range 4.88-5.5
7	8	10012-007	LFN 1/2-13, Gr. G	36	4	10855-002	Vinyl-Coated Loop Clamp, 1" ID
8	22	10012-008	LFN 5/8-11 Gr G	37	6	10855-003	Vinyl-Coated Loop Clamp, 5/8" ID
9	20	10012-010	LFN 5/16-18, Gr. G	38	2	10867-003	Jounce Bumper, 2.375"Dia x 3.00"T
10	9	10012-012	LFN 3/4-16, Gr. G	39	16	10874-200	HFB 5/8-11x2.000, Gr. 8
11	16	10012-014	LFN 3/4-10 Gr G	40	2	10874-375	HFB 5/8-11x3.750, Gr. 8
12	4	10064-005	U-Bolt 3/4-16 x 9.03 Tri-8	41	2	10874-500	HFB 5/8-11x5.000, Gr. 8
13	1	10474-001	Silicone Oil, 16 oz. Bottle	42	2	10874-600	HFB 5/8-11 x 6", Gr. 8
14	8	10501-002	HFB 3/8-16 x 1.250 Gr 8	43	8	10885-150	HFB 1/2-13x1.500, Gr. 8
15	2	10502-001	HFB M10-1.5 x 30 CL 10.9	44	18	10886-125	HFB 5/16-18 x 1.25, Gr. 8
16	2	10570-005	UCA (17.896)	45	2	10947-005	Lower Axle Clamp
17	3	10586-001	Sensor	46	2	10949-003	Upper Axle Clamp
18	3	10587-006	Linkage, 3.938" SS	47	2	10953-004	Lower Control Arm
19	2	10591-003	Ball Stud 5/16-18 x .75L	48	1	11013-004	Power Supply, Side Mount
20	1	10597-071	Volume Asy, LH	49	1	11057-003	Strut
21	1	10597-072	Volume Asy, RH	50	1	11057-004	Strut
22	1	10614-001	Cap, Filler/Breather	51	12	11102-250	HFB 3/4-10 x 2-1/2 Gr 8
23	8	10640-005	Bearing Spacer, 1.24 x .812 x .318	52	2	11102-400	HFB 3/4-10 x 4 Gr 8
24	1	10680-001	Driver Interface	53	2	11102-650	HFB 3/4-10 x 6-1/2 Gr 8
25	1	10704-009	Wiring Harness, Dash, M2	54	1	11104-001	LH Front Hanger
26	1	10733-004	Steering Linkage Mnt	55	1	11105-001	RH Front Hanger
27	1	10741-005	Steering Sensor Mnt	56	1	11109	Kit, Power Module Mounting
28	1	10790-012	Upper Strut Mount, LH	57	1	11113	Kit, Drawing, Freightliner M2
29	1	10790-013	Upper Strut Mount, RH	58	4	11689-001	Spacer, Plastic, M2
30	1	10795-008	Mount, Crossmember, LH				

Front Hangers

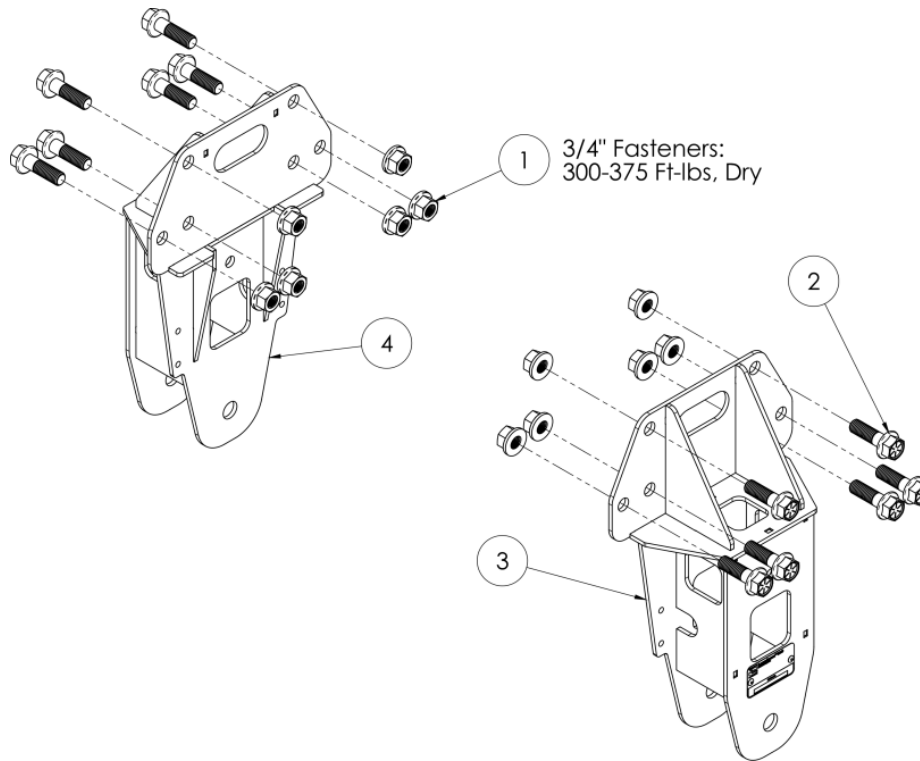

ITEM	QTY	PART NUMBER	DESCRIPTION	ITEM	QTY	PART NUMBER	DESCRIPTION
1	12	10012-014	LFN 3/4-10 Gr G	3	1	11104-001	Left Hand Hanger
2	12	11102-250	HFB 3/4-10 x 2-1/2 Gr 8	4	1	11105-001	Right Hand Hanger

Jounce Stops

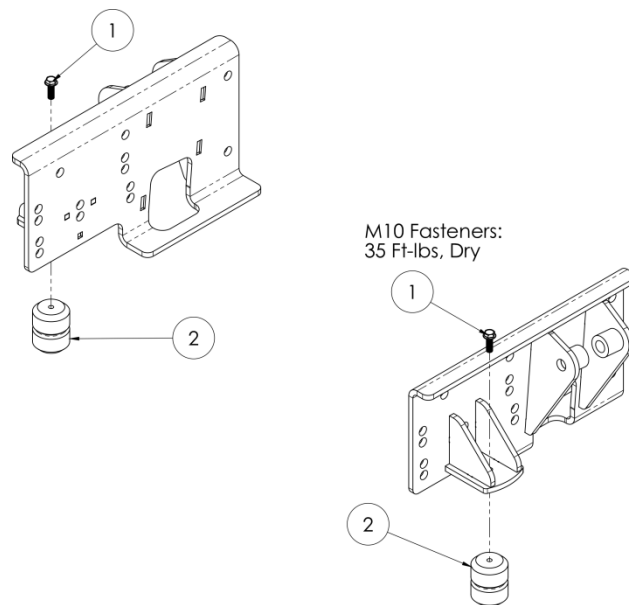

ITEM	QTY	PART NUMBER	DESCRIPTION	ITEM	QTY	PART NUMBER	DESCRIPTION
1	2	10502-001	HFB M10-1.5 x 30 CL 10.9	1	2	10867-003	Jounce Bumper 2.375" OD x 3.00" T

Axle Connection

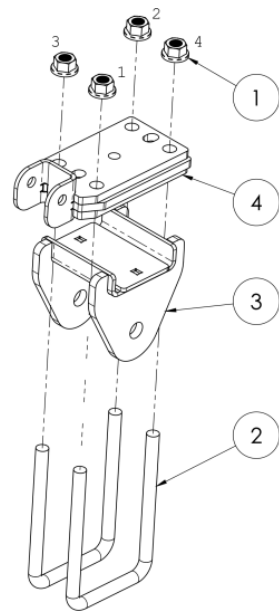

- Torque U-Bolts Evenly
1. Tighten all U-bolts until snug only.
 2. Tighten in sequence 1-2-3-4 to 100 ft-lbs
 3. Tighten in sequence 1-2-3-4 to 200 ft-lbs
 4. Tighten in sequence 1-2-3-4 to 300 ft-lbs

See U-bolt
Torque Sequence

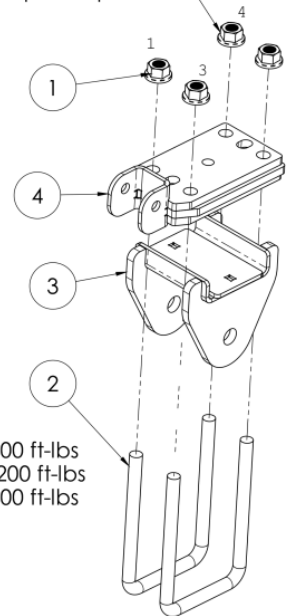

ITEM	QTY	PART NUMBER	DESCRIPTION	ITEM	QTY	PART NUMBER	DESCRIPTION
1	8	10012-012	LFN 3/4-16, Gr. G	3	2	10947-005	Lower Control Arm Mount
2	4	10064-005	U-Bolt 3/4-16 x 9.03 Tri-8	4	2	10949-003	Upper Control Arm Mount

Control Arms

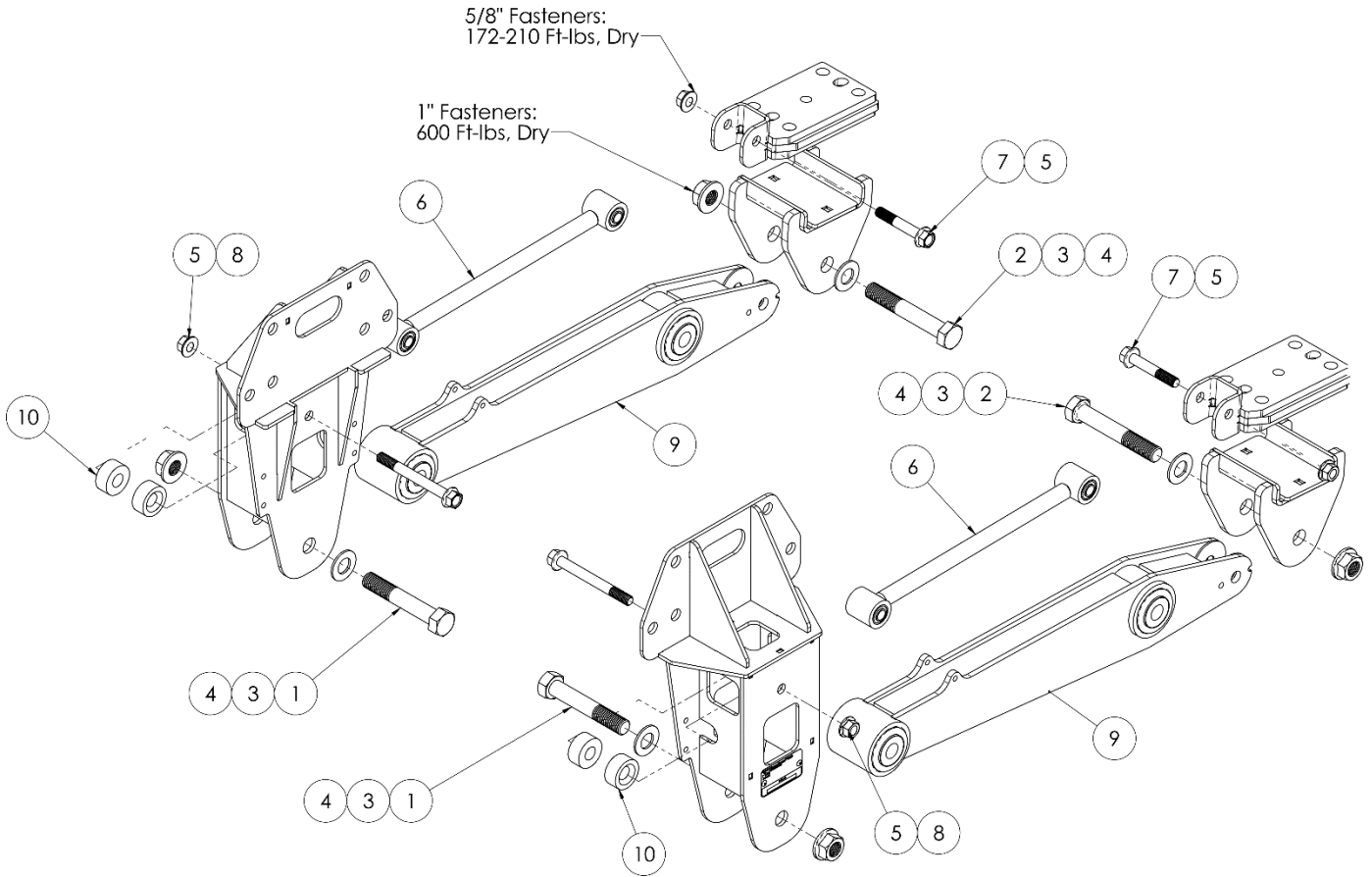

ITEM	QTY	PART NUMBER	DESCRIPTION	ITEM	QTY	PART NUMBER	DESCRIPTION
1	2	10003-003	HCS 1-8 x 6.00 Gr 8	6	2	10570-005	Upper Control Arm
2	2	10003-004	HCS 1-8 x 6.50 Gr 8	7	2	10874-375	HFB 5/8-11 x 3.750 Gr 8
3	4	10006-004	HFW 1	8	2	10874-600	HFB 5/8-11 x 6" Gr. 8
4	4	10012-003	LFN 1-8 Gr G	9	2	10953-004	Lower Control Arm
5	4	10012-008	LFN 5/8-11 Gr G	10	4	11689-001	Spacer, Plastic, M2

Upper Strut Mounts

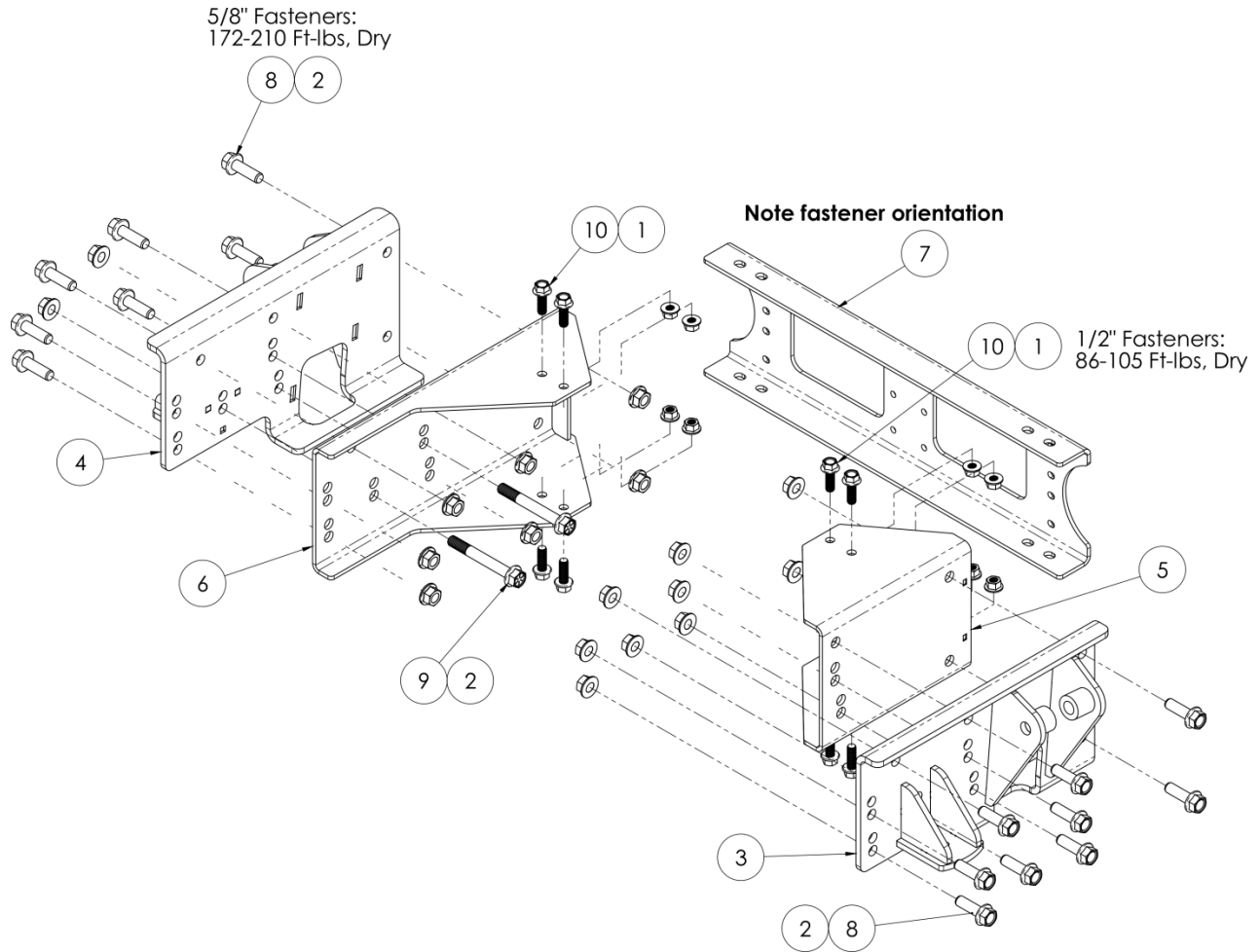

ITEM	QTY	PART NUMBER	DESCRIPTION	ITEM	QTY	PART NUMBER	DESCRIPTION
1	8	10012-007	LFN 1/2-13 Gr G	6	1	10795-009	Cross-member Mount, RH
2	18	10012-008	LFN 5/8-11 Gr G	7	1	10796-007	Cross-member Channel
3	1	10790-012	Upper Strut Mount, LH	8	16	10874-200	HFB 5/8-11 x 2" Gr 8
4	1	10790-013	Upper Strut Mount, RH	9	2	10874-500	HFB 5/8-11 x 5" Gr 8
5	1	10795-008	Cross-member Mount, LH	10	8	10885-150	HFB 1/2-13 x 1-1/2" Gr 8

Struts

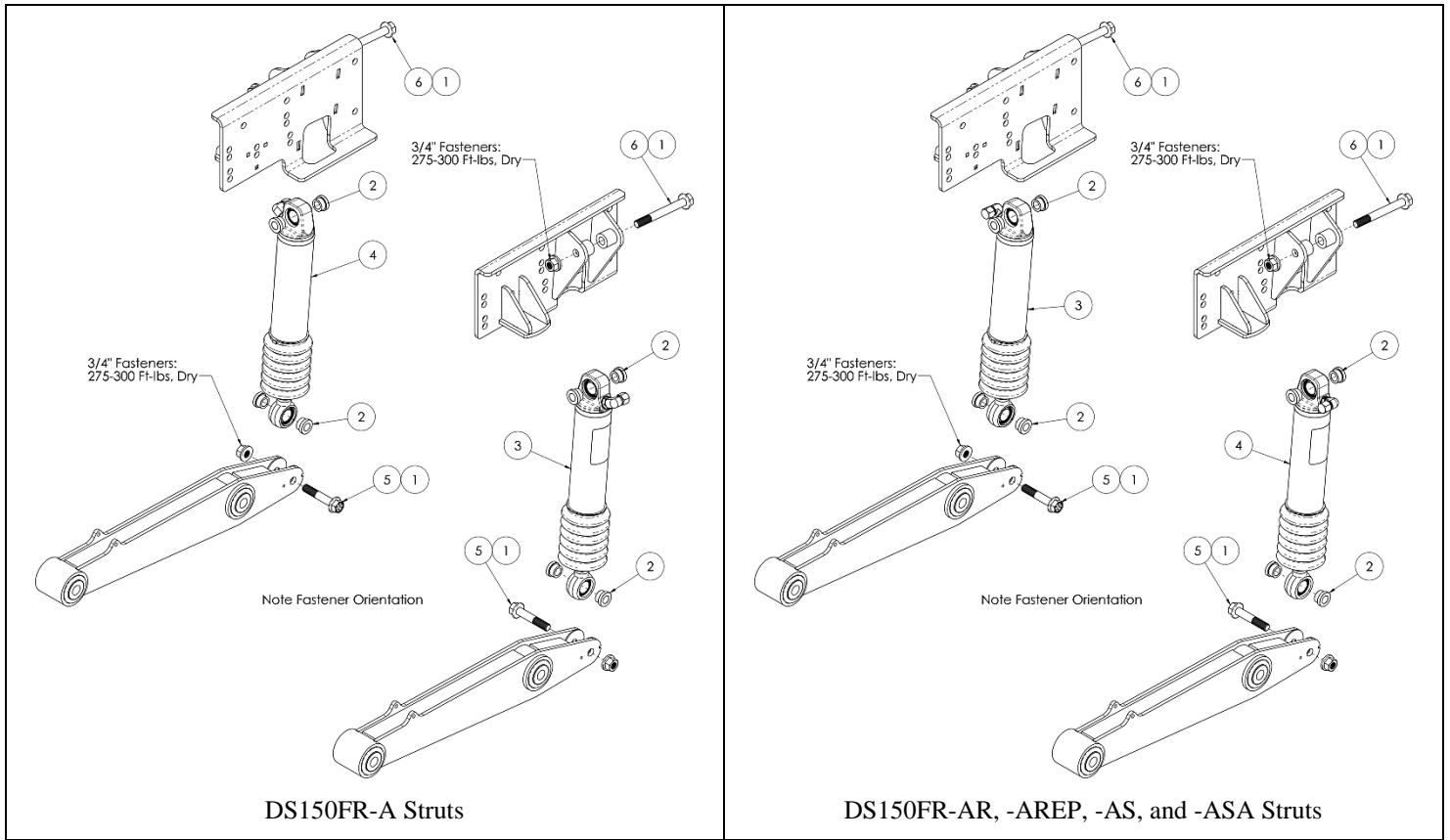

ITEM	QTY	PART NUMBER	DESCRIPTION	ITEM	QTY	PART NUMBER	DESCRIPTION
1	4	0012-014	LFN 3/4-10 Gr G	4	1	11057-004	Strut Asy (fitting pointing Left)
2	8	10640-005	Bearing Spacer 1.24x.812x.318	5	2	11102-400	HFB 3/4-10 x 4 Gr 8
3	1	11057-003	Strut Asy (fitting pointing Right)	6	2	11102-650	HFB 3/4-10 x 6-1/2 Gr 8

Secondary Volumes [DS150FR-A]

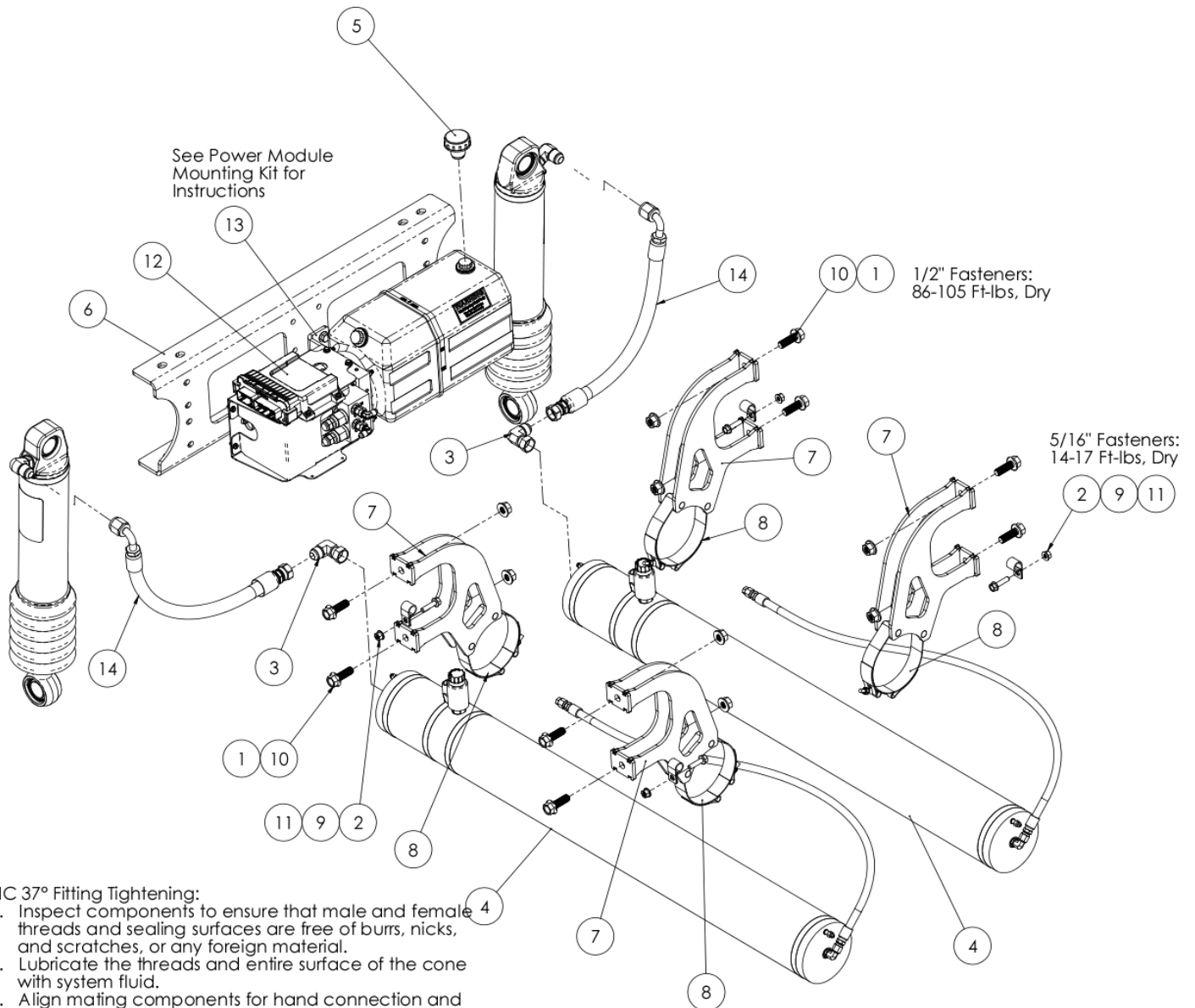

JIC 37° Fitting Tightening:

1. Inspect components to ensure that male and female threads and sealing surfaces are free of burrs, nicks, and scratches, or any foreign material.
2. Lubricate the threads and entire surface of the cone with system fluid.
3. Align mating components for hand connection and turn flare nut until sealing surfaces make full contact.
4. Using two wrenches, hold fitting in desired position and tighten -10 fitting to 36-63 ft-lbs.
5. Clean off fittings and check for leaks.

ITEM	QTY	PART NUMBER	DESCRIPTION	ITEM	QTY	PART NUMBER	DESCRIPTION
1	8	10012-007	LFN 1/2-13 Gr G	8	4	10843-003	T-Bolt Clamp
2	4	10012-010	LFN 5/16-18 Gr G	9	4	10855-003	Vinyl Coated Loop 5/8" ID
3	2	10322-010	Hyd. Fitting 90 -10 37 x -10 37 F	10	4	10885-150	HFB 1/2"-13 x 1-1/2" Gr 8
4	2	10597-047	Volume Asy	11	8	10886-125	HFB 5/16"-18 x 1-1/4" Gr 8
5	1	10614-001	Cap, Filler/Breather	12	4	11013-004	Power Module Asy DS150FR
6	1	10796-007	Cross-member Channel	13	1	11109	Power Module Mounting Kit
7	4	10830-017	Volume Mount	14	2	11458-019	Asy, Hose -10 x 19" L

Power Module [DS150FR-A]

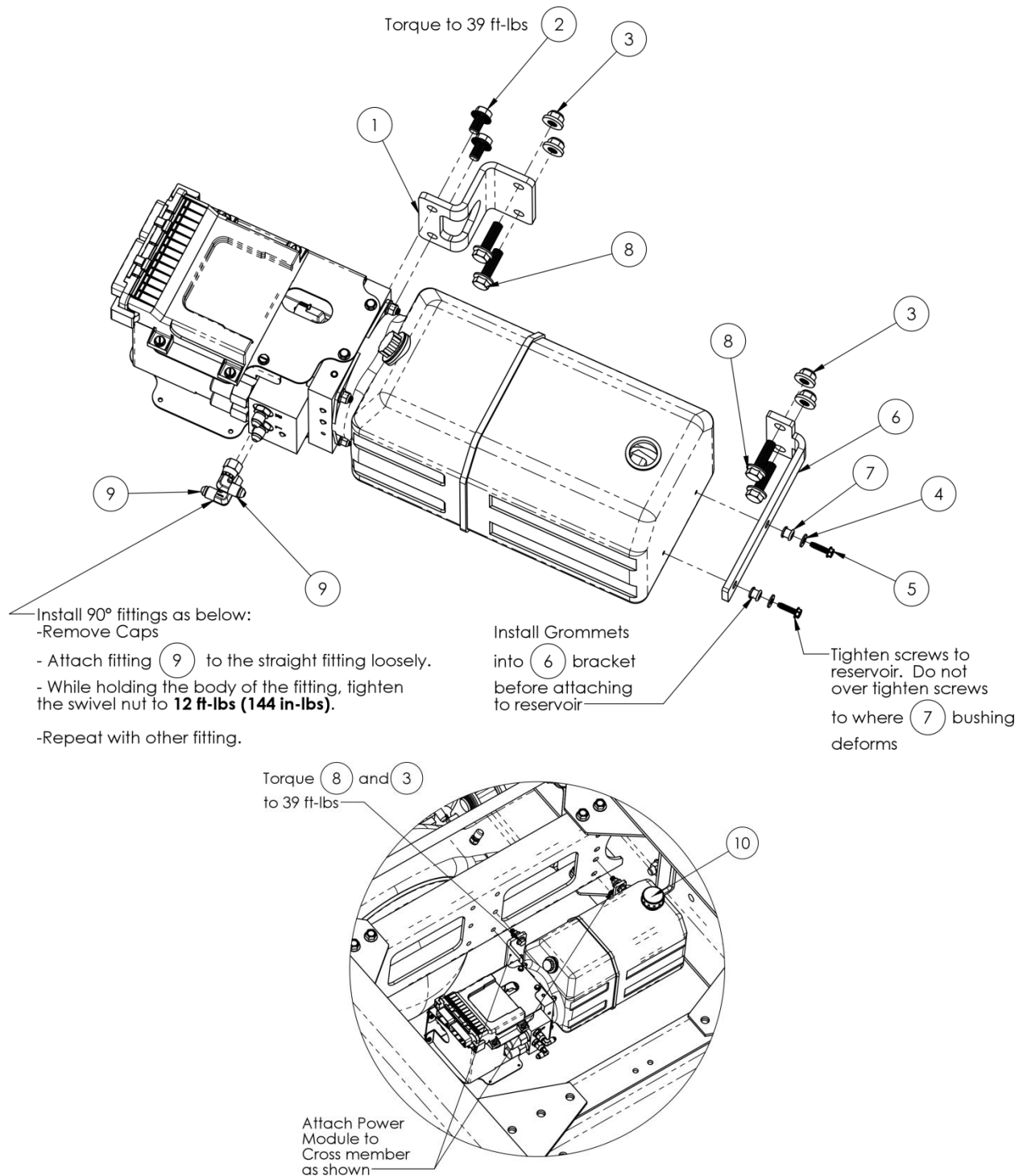

ITEM	QTY	PART NUMBER	DESCRIPTION	ITEM	QTY	PART NUMBER	DESCRIPTION
1	1	10799-015	Power Module Manifold Mount	6	1	10798-015	Power Module Reservoir Mount
2	2	10252-003	SFHS 3/8"-16 x 5/8" Gr 8	7	2	10805-007	Grommet
3	4	10012-011	LFN 3/8"-16 Gr G	8	4	10501-002	HFB 3/8"-16 x 1-1/4" Gr 8
4	2	10088-001	FW #10	9	2	10322-021	Hyd. Fit. 90, -4 37 x -4 37 F
5	2	10510-002	STS #10-16 x 3/4" Hex Head	10*	1	10614-001	Cap, Filler/Breather

*P/N 10614-001 is included in the main kit.

Hose Attachment and Routing [DS150FR-A]

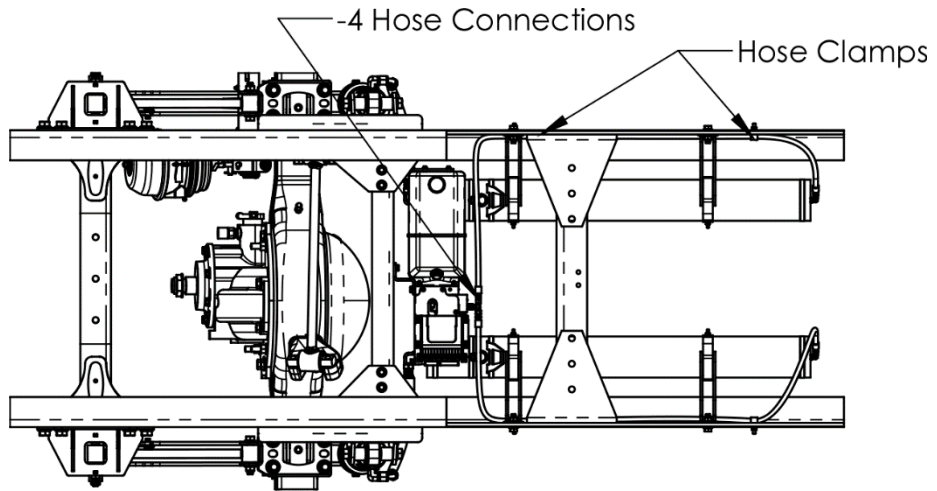

Figure 6. DS150FR-A -4 Hose Routing (Top View)

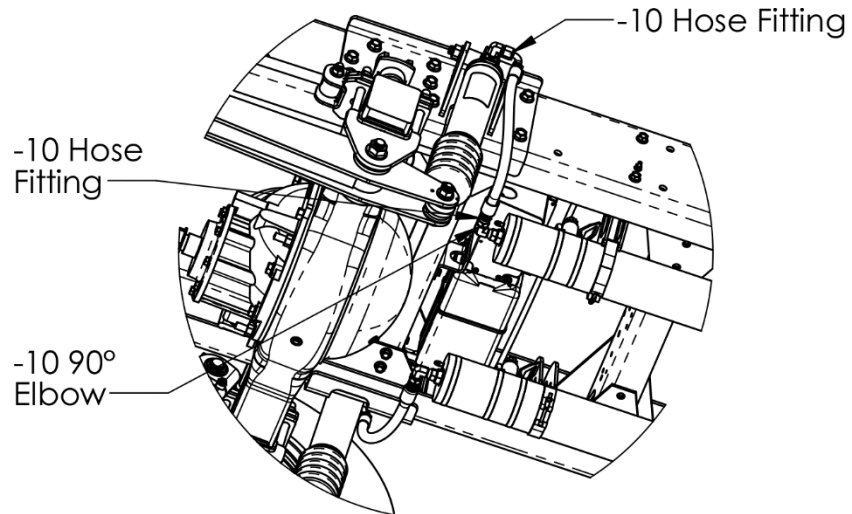
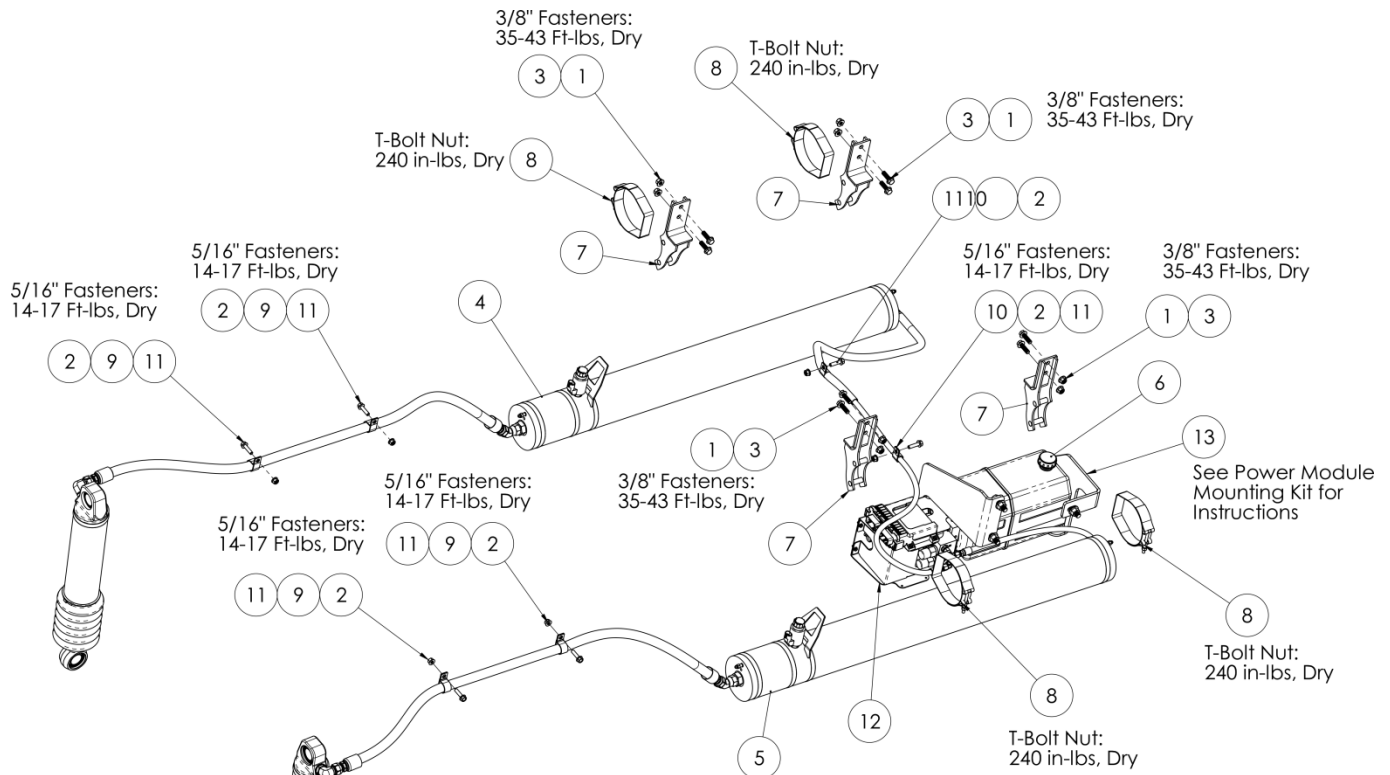

Figure 7. DS150FR-A -10 Hose Routing (Bottom View)

Secondary Volumes (DS150FR-AR)



JIC 37° Fitting Tightening:

1. Inspect components to ensure that male and female threads and sealing surfaces are free of burrs, nicks, and scratches, or any foreign material.
2. Lubricate the threads and entire surface of the cone with system fluid.
3. Align mating components for hand connection and turn flare nut until sealing surfaces make full contact.
4. Using two wrenches, hold fitting in desired position and tighten -10 fitting to 36-63 ft-lbs.
5. Clean off fittings and check for leaks.

ITEM	QTY	PART NUMBER	DESCRIPTION	ITEM	QTY	PART NUMBER	DESCRIPTION
1	8	10012-005	LFN 3/8"-16 Gr G	8	4	10843-003	T-Bolt Clamp
2	6	10012-010	LFN 5/16"-18 Gr G	9	4	10855-002	Vinyl Coated Loop Clamp, 1" ID
3	8	10501-002	HFB 3/8"-16 x 1-1/4" Gr 8	10	2	10855-003	Vinyl Coated Loop Clamp, 5/8" ID
4	1	10597-051	Volume Assembly, LH	11	6	10886-125	HFB 5/16"-18 x 1-1/4" Gr 8
5	1	10597-0152	Volume Assembly, RH	12	1	11013-004	Power Module Asy DS150FR
6	1	10614-001	Cap, Filler/Breather	13	1	11129	Power Module Mount Kit
7	4	10830-015	Volume Mount				

Secondary Volumes [DS150FR-AREP]

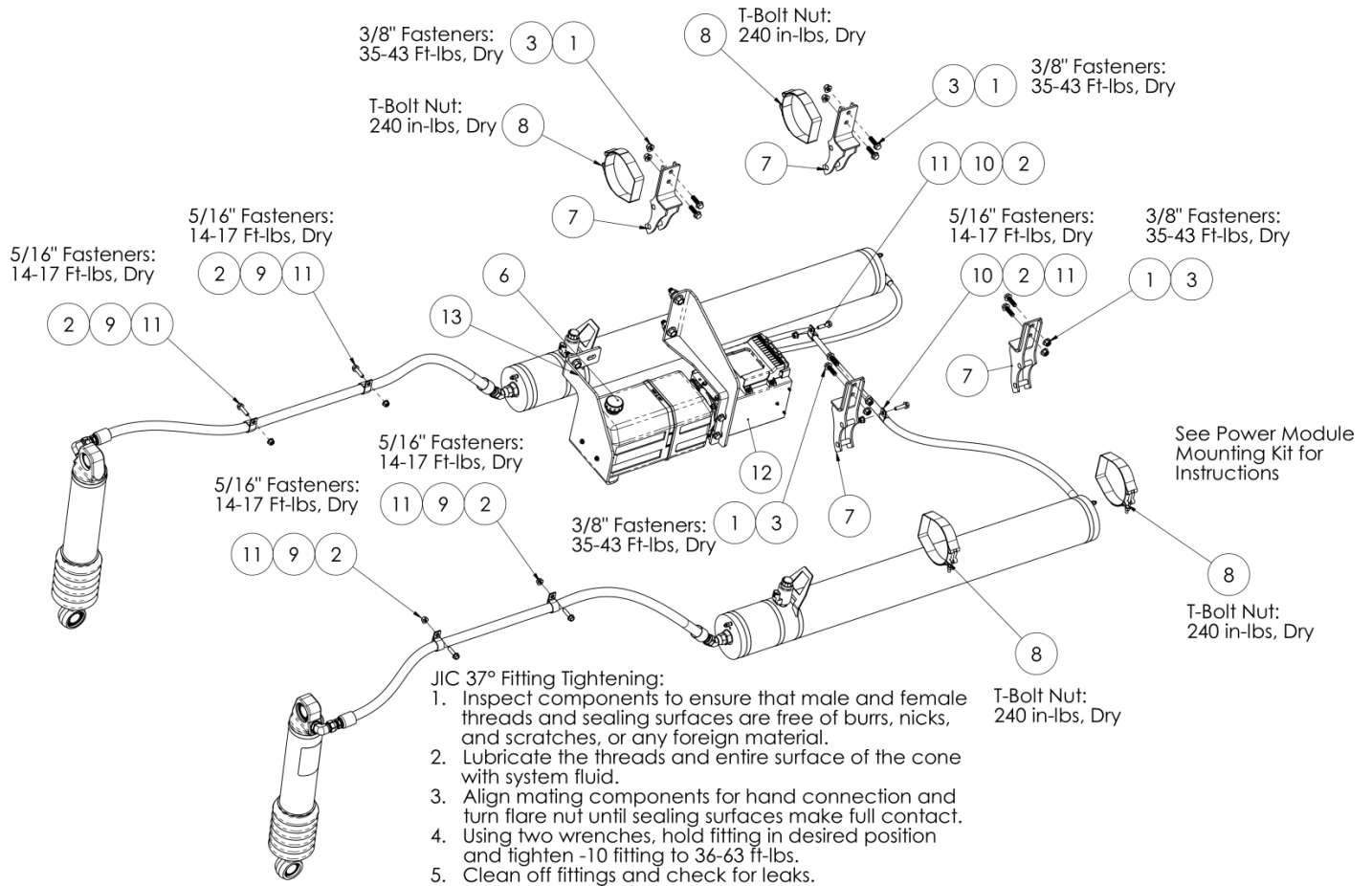

ITEM	QTY	PART NUMBER	DESCRIPTION	ITEM	QTY	PART NUMBER	DESCRIPTION
1	8	10012-005	LFN 3/8"-16 Gr G	8	4	10843-003	T-Bolt Clamp
2	6	10012-010	LFN 5/16"-18 Gr G	9	4	10855-002	Vinyl Coated Loop Clamp, 1" ID
3	8	10501-002	HFB 3/8"-16 x 1-1/4" Gr 8	10	2	10855-003	Vinyl Coated Loop Clamp, 5/8" ID
4	1	10597-055	Volume Assembly, LH	11	6	10886-125	HFB 5/16"-18 x 1-1/4" Gr 8
5	1	10597-056	Volume Assembly, RH	12	1	11013-004	Power Module Asy DS150FR
6	1	10614-001	Cap, Filler/Breather	13	1	11129	Power Module Mount Kit
7	4	10830-015	Volume Mount				

Power Module [DS150FR-AR and DS150FR-AREP]

Install 90° fitting as below:

- Remove caps
- Attach fitting (4) to the straight fitting loosely
- While holding the body of the fitting, tighten the swivel nut to **12 ft-lbs (144 in-lbs)**
- Repeat with other fitting.

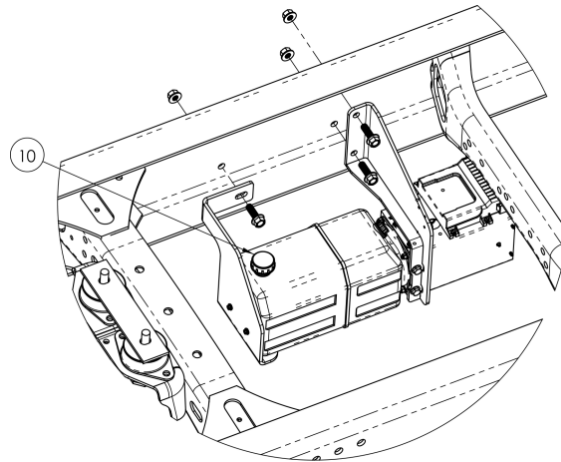
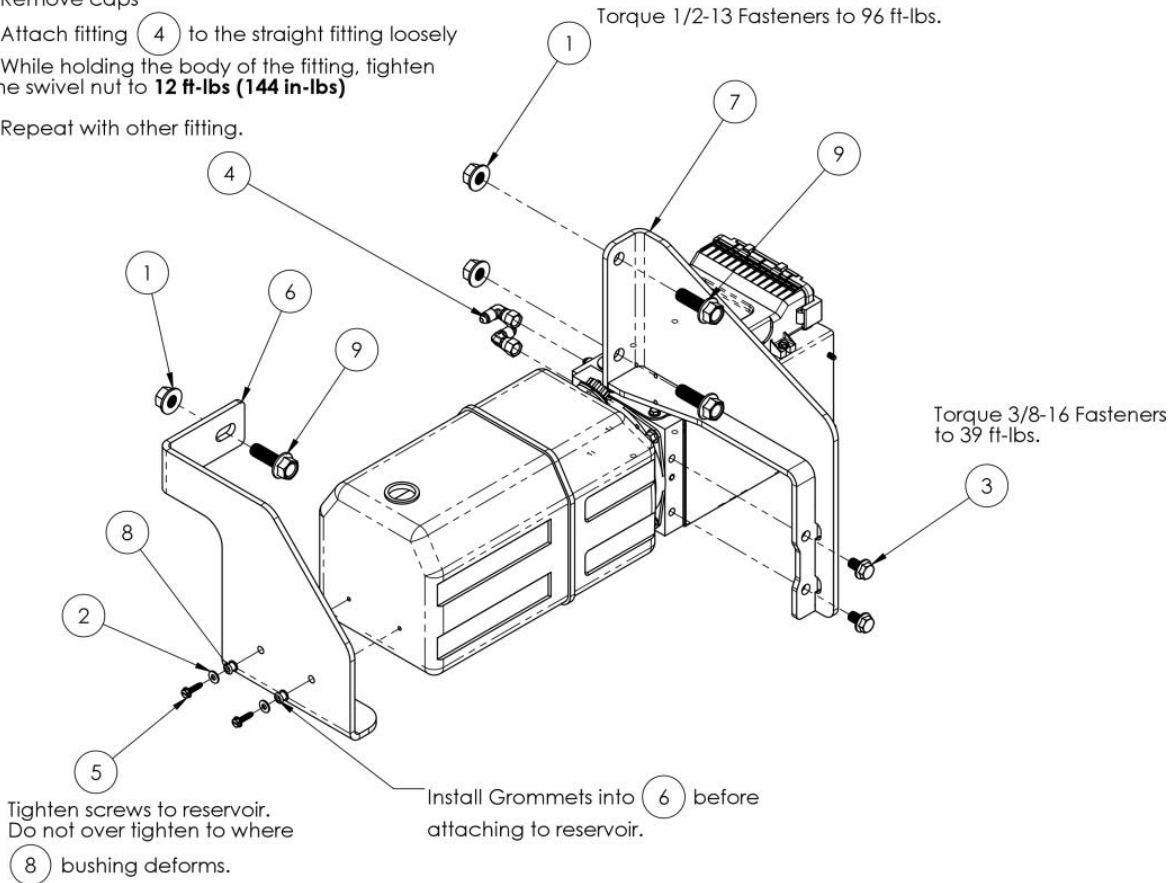

(DS150FR-AR Shown. DS150FR-AREP similar on Driver Side)

ITEM	QTY	PART NUMBER	DESCRIPTION	ITEM	QTY	PART NUMBER	DESCRIPTION
1	3	10012-007	LFN 1/2"-13 Gr G	6	1	10798-016	Power Module Reservoir Mount
2	2	10088-001	FW #10	7	1	10799-016	Power Module Manifold Mount
3	2	10252-003	SFHS 3/8"-16 x 5/8" Gr 8	8	2	10805-007	Grommet
4	2	10322-021	Hyd. Fit. 90, -4 3/8 x -4 3/8 F	9		10885-150	HFB 1/2"-13 x 1-1/2" Gr 8
5	2	10510-002	STS #10-16 x 3/4" Hex Head	10*	1	10614-001	Cap, Filler/Breather

*P/N 10614-001 is included in the main kit.

Hose Attachment and Routing [DS150FR-AR and DS150FR-AREP]

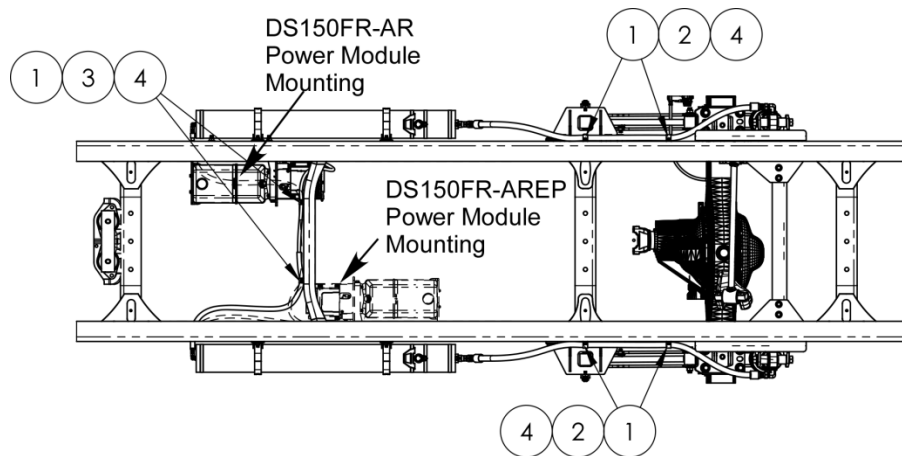

ITEM	QTY	PART NUMBER	DESCRIPTION	ITEM	QTY	PART NUMBER	DESCRIPTION
1	2	10012-010	LFN 5/16"-18 Gr G	3	3	10855-003	Vinyl Coated Loop Clamp, 5/8" ID
2	4	10855-002	Vinyl Coated Loop Clamp, 1" ID	4	2	10886-100	HFB 5/16-18 x 1.000" Grade 8

Secondary Volumes [DS150FR-AS / -ASA]

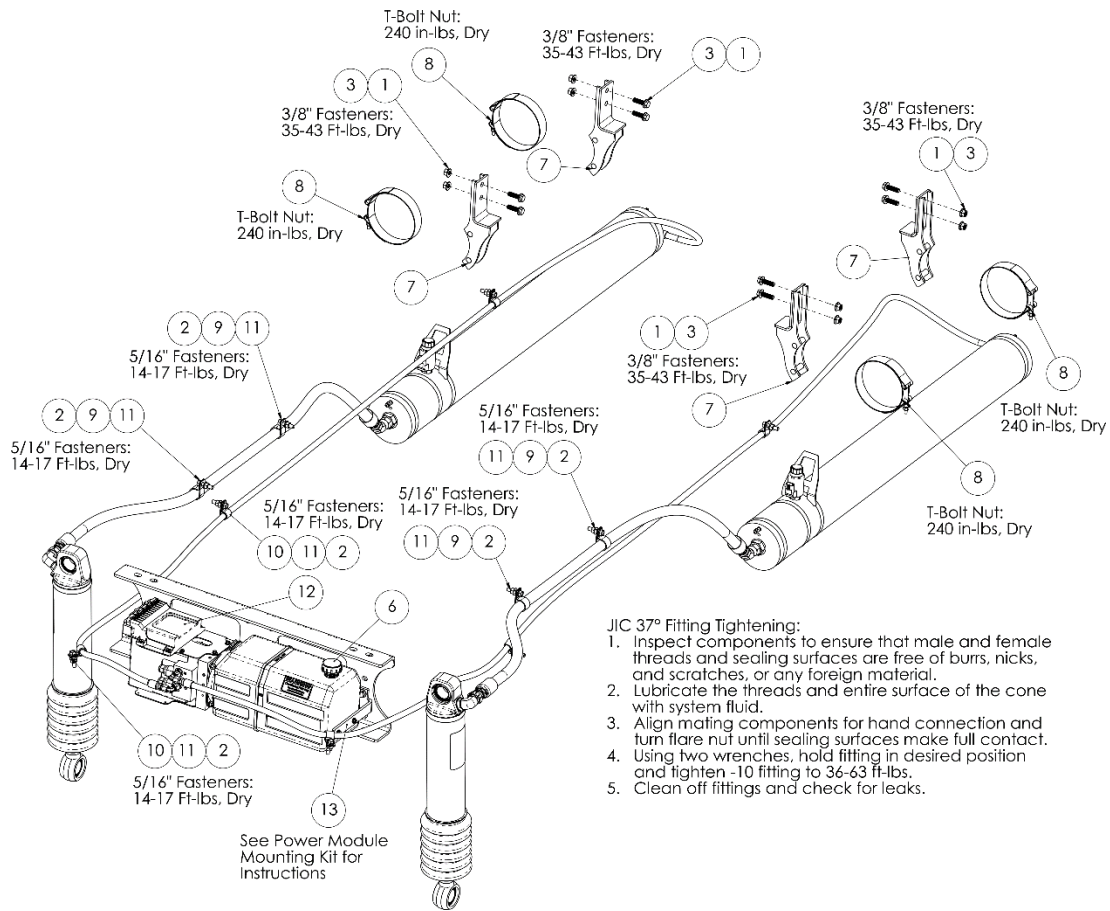

ITEM	QTY	PART NUMBER	DESCRIPTION	ITEM	QTY	PART NUMBER	DESCRIPTION
1	8	10012-005	LFN 3/8"-16 Gr G, Z	8	4	10843-003	T-Bolt Clamp, Range 4.88-5.5
2	10	10012-010	LFN 5/16"-18 Gr G	9	4	10855-002	Vinyl-Coated Loop Clamp, 1" ID
3	8	10501-002	HFB 3/8-16 x 1.250, Gr 8, BO	10	6	10855-003	Vinyl-Coated Loop Clamp, 5/8" ID
4	1	10597-071	Volume Assembly, LH	11	10	10886-125	HFB 5/16"-18 x 1-1/4" Gr 8
5	1	10597-072	Volume Assembly, RH	12	1	11013-004	Power Module Asy M2
6	1	10614-001	Cap, Filler/Breather	13	1	11109	Power Module Mount Kit
7	4	10830-015	Wldmnt, Volume Mount (-AS)				
		10830-013	Wldmnt, Volume Mount (-ASA)				

Power Module [DS150FR-AS / -ASA]

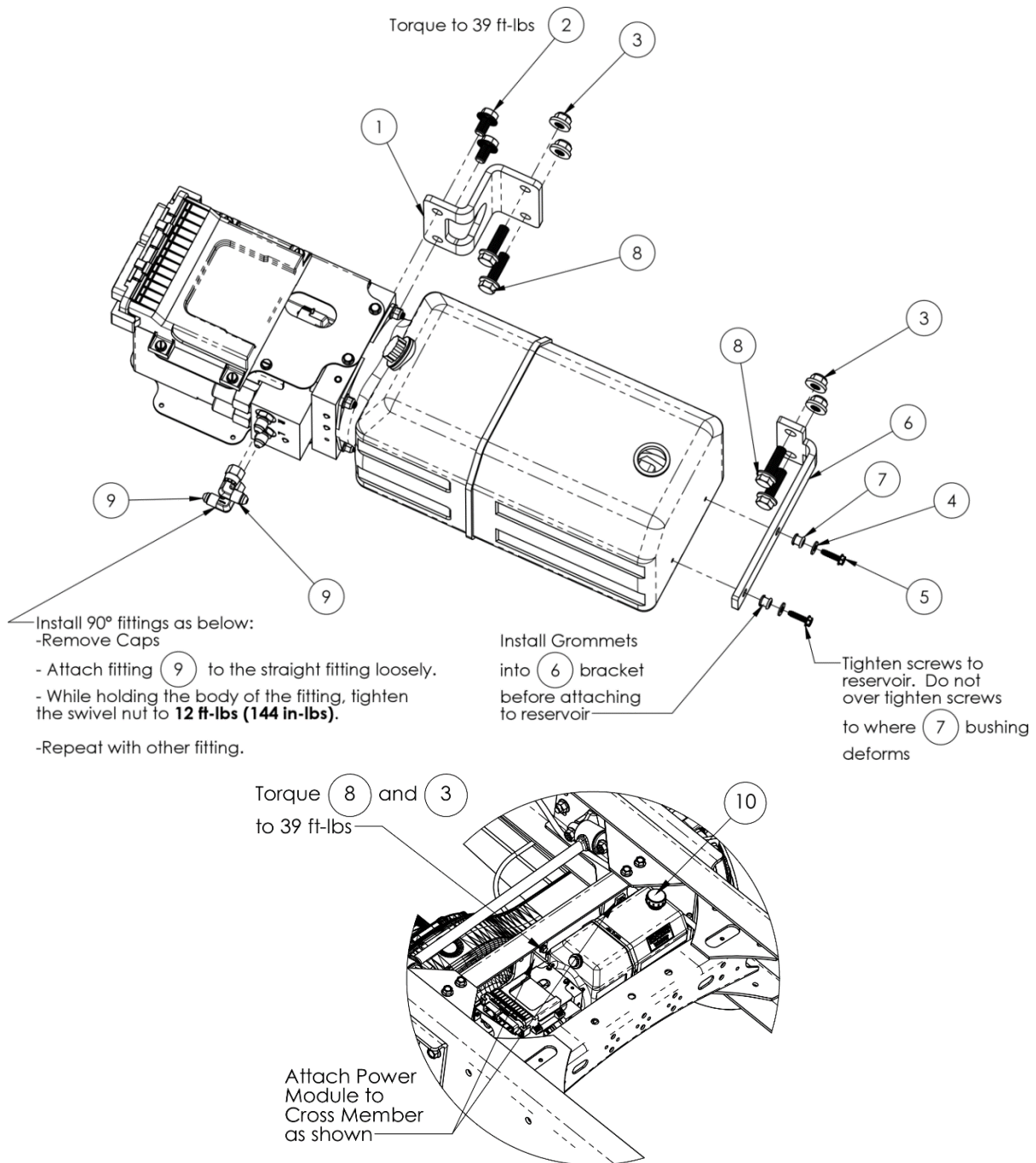

ITEM	QTY	PART NUMBER	DESCRIPTION	ITEM	QTY	PART NUMBER	DESCRIPTION
1	1	10799-015	Power Module Manifold Mount	6	1	10798-015	Power Module Reservoir Mount
2	2	10252-003	SFHS 3/8"-16 x 5/8" Gr 8	7	2	10805-007	Grommet
3	4	10012-011	LFN 3/8"-16 Gr G	8	4	10501-002	HFB 3/8"-16 x 1-1/4" Gr 8
4	2	10088-001	FW #10	9	2	10322-021	Hyd. Fit. 90, -4 37 x -4 37 F
5	2	10510-002	STS #10-16 x 3/4" Hex Head	10*	1	10614-001	Cap, Filler/Breather

Hose Attachment & Routing [DS150FR-AS / -ASA]

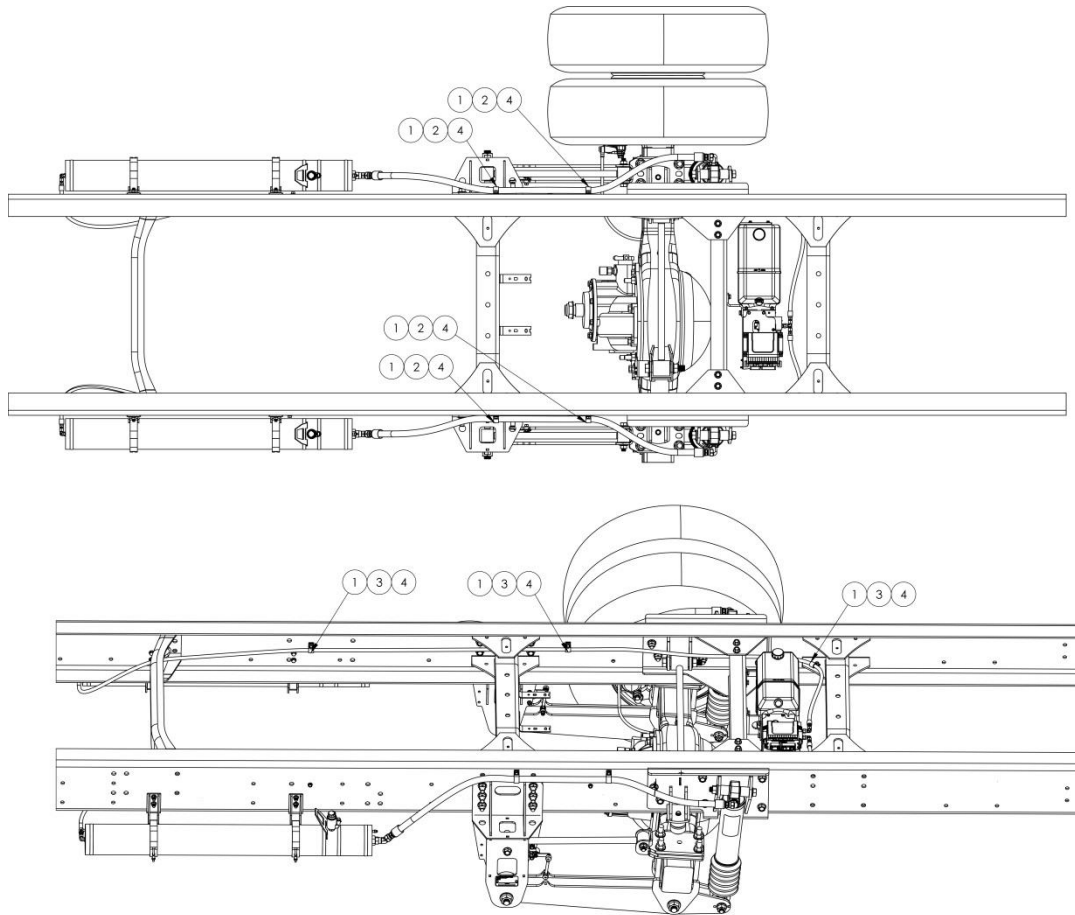

* Driver Side has same hose routing as Passenger side

ITEM	QTY	PART NUMBER	DESCRIPTION	ITEM	QTY	PART NUMBER	DESCRIPTION
1	10	10012-010	LFN 5/16"-18 Gr G	3	6	10855-003	Vinyl Coated Loop Clamp, 5/8" ID
2	4	10855-002	Vinyl Coated Loop Clamp, 1" ID	4	10	10886-100	HFB 5/16-18 x 1.000" Grade 8

Height Sensors

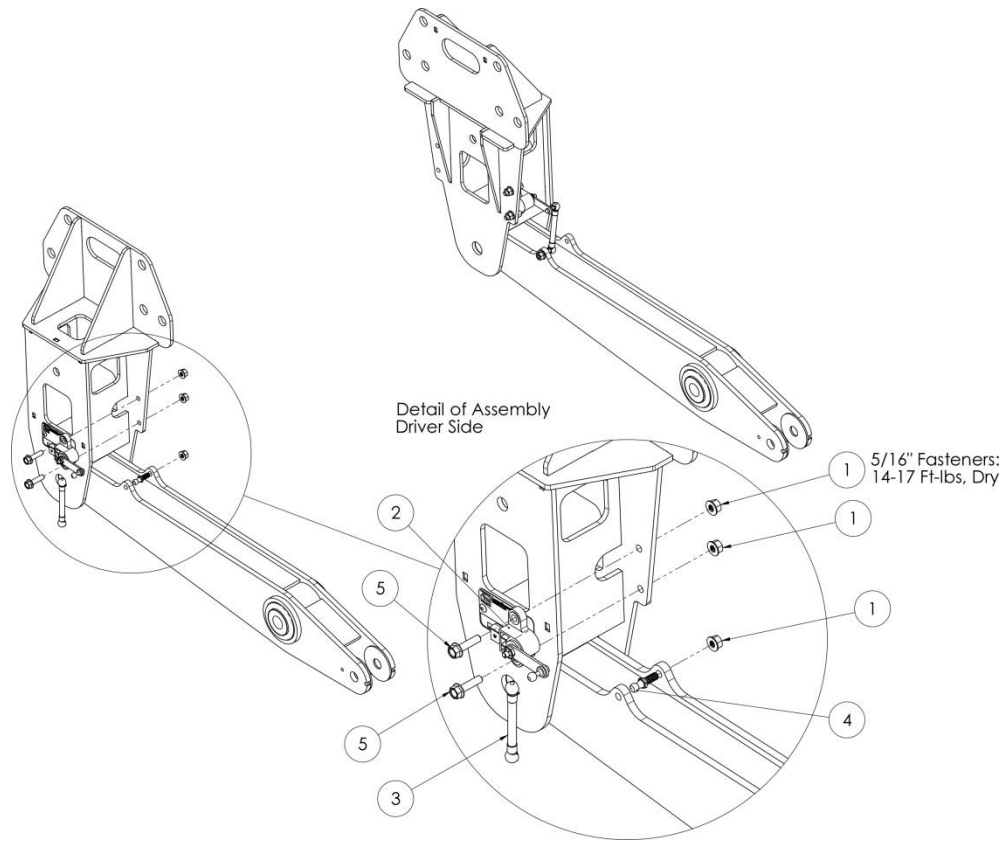

ITEM	QTY	PART NUMBER	DESCRIPTION	ITEM	QTY	PART NUMBER	DESCRIPTION
1	6	10012-010	LFN 5/16-18 Gr G	4	2	10591-003	Ball Stud, 5/16-18 x .75L
2	2	10586-001	Asy, Height Sensor	5	4	10886-125	HFB 5/16-18 x 1.25 Gr 8
3	2	10587-006	Asy, Linkage, 3.938" SS				

Steering Sensors

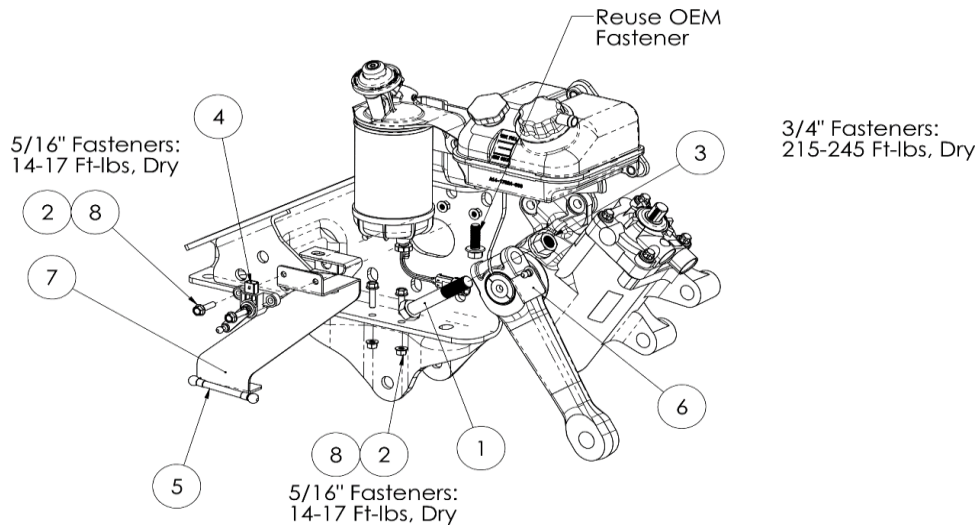

2019 and Later

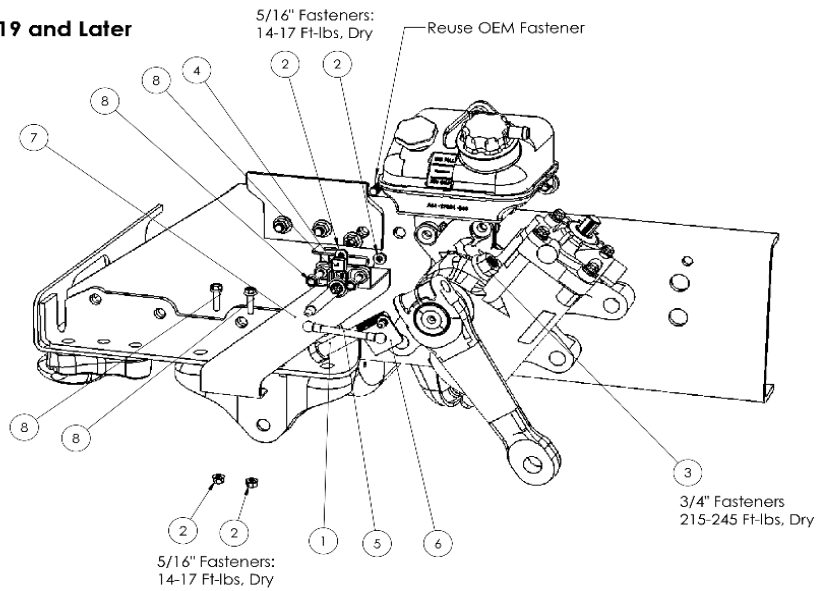

ITEM	QTY	PART NUMBER	DESCRIPTION	ITEM	QTY	PART NUMBER	DESCRIPTION
1	1	10001-005	HB 3/4"-16x4-1/2" Gr 8	5	1	10587-006	Asy, Linkage 3.938" SS
2	4	10012-010	LFN 5/16"-18 Gr G	6	1	10733-004	Steering Linkage Mount
3	1	10012-012	LFN 3/4"-16 Gr G	7	1	10741-005	Steering Sensor Mount
4	1	10586-001	Height /Steering Sensor	8	4	10886-125	HFB 5/16"-18 x 1-1/4" Gr8

Electrical Schematics

Schematic, Dash Wiring Harness

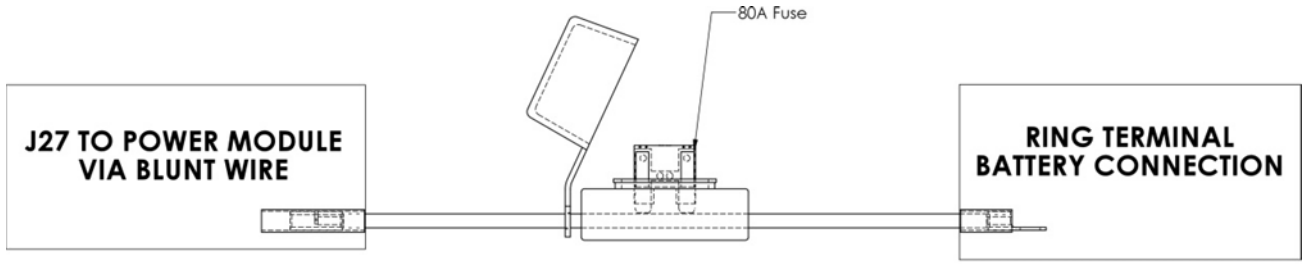
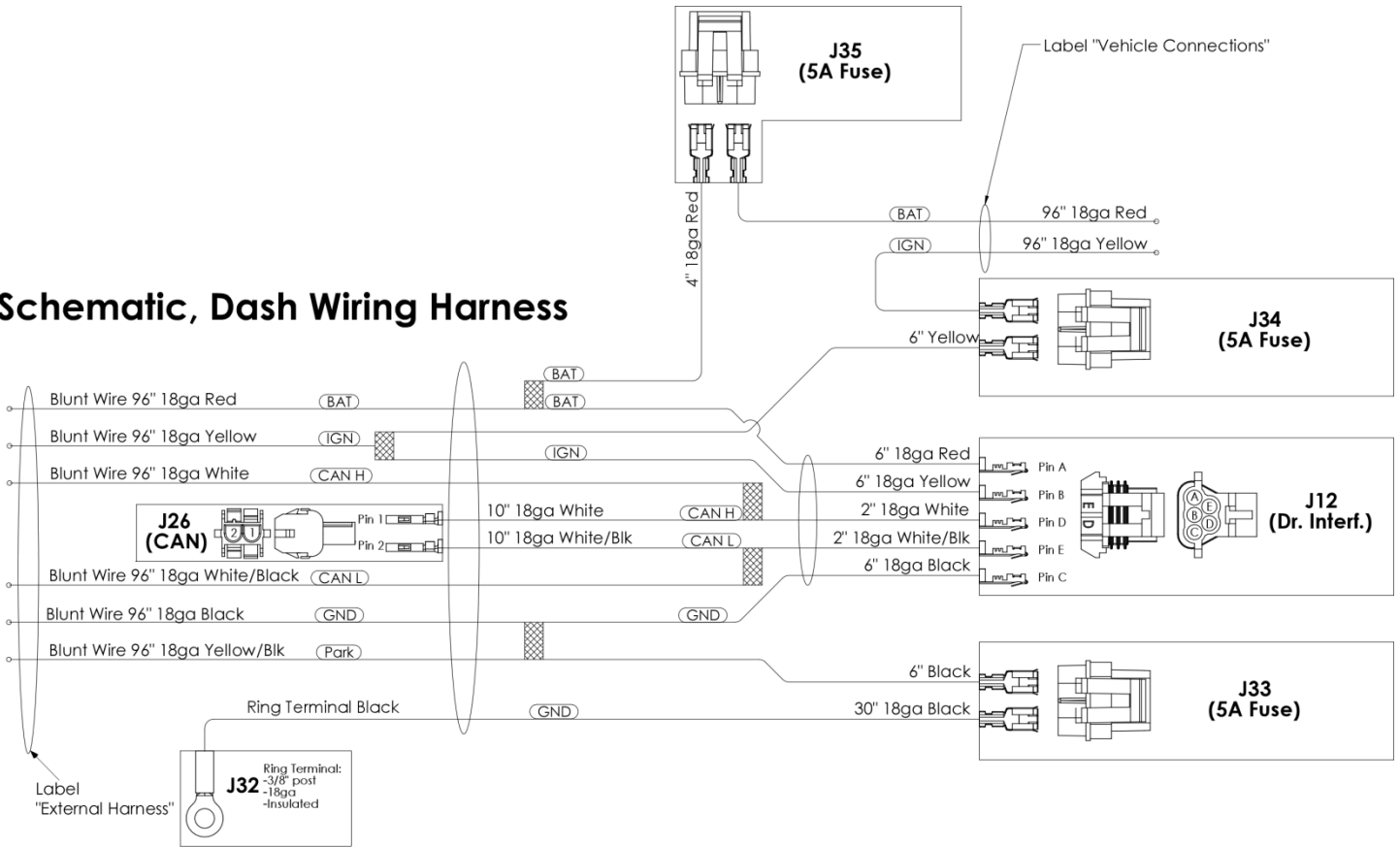

Schematic, Battery Fuse Lead

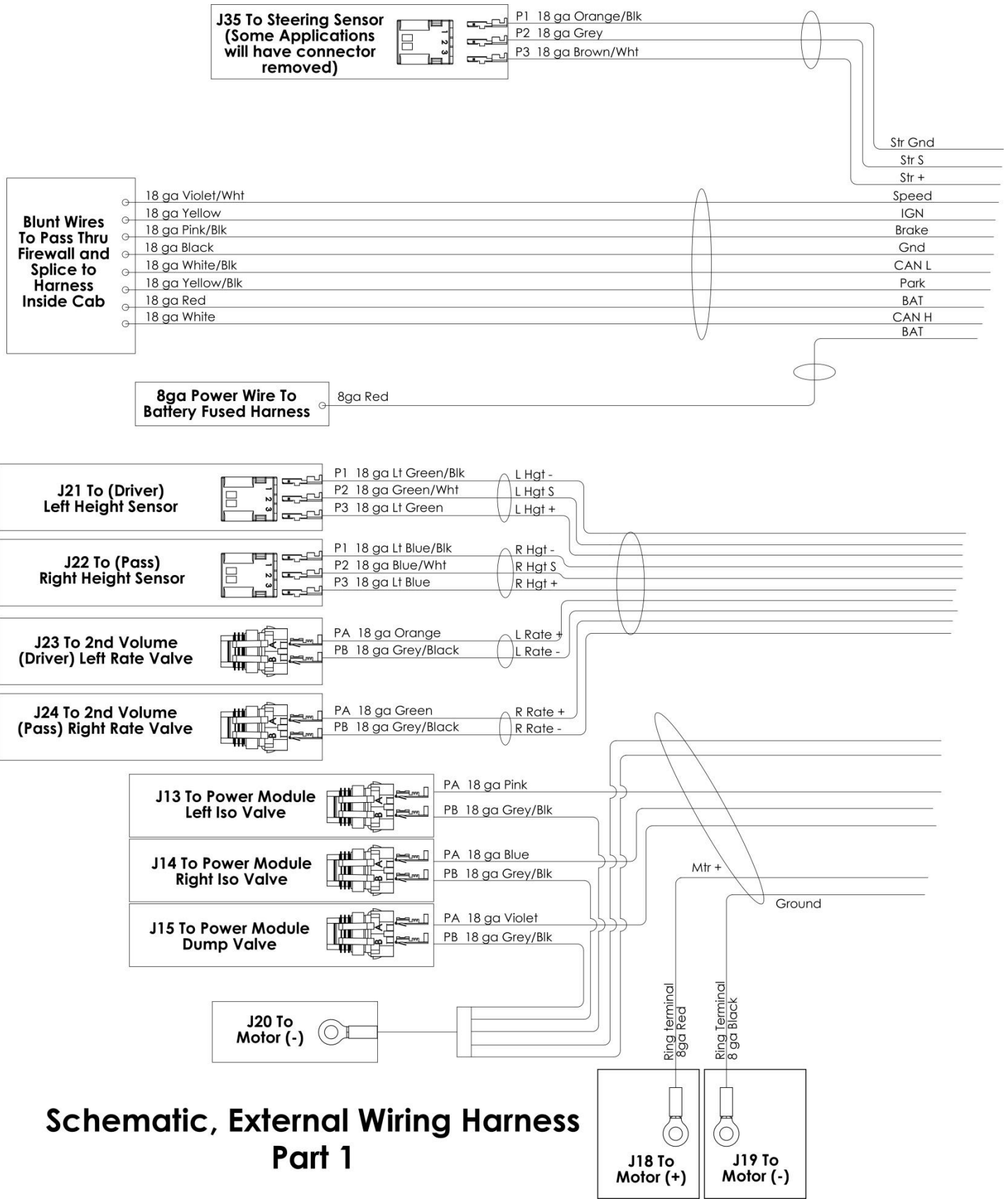

Schematic, External Wiring Harness Part 1

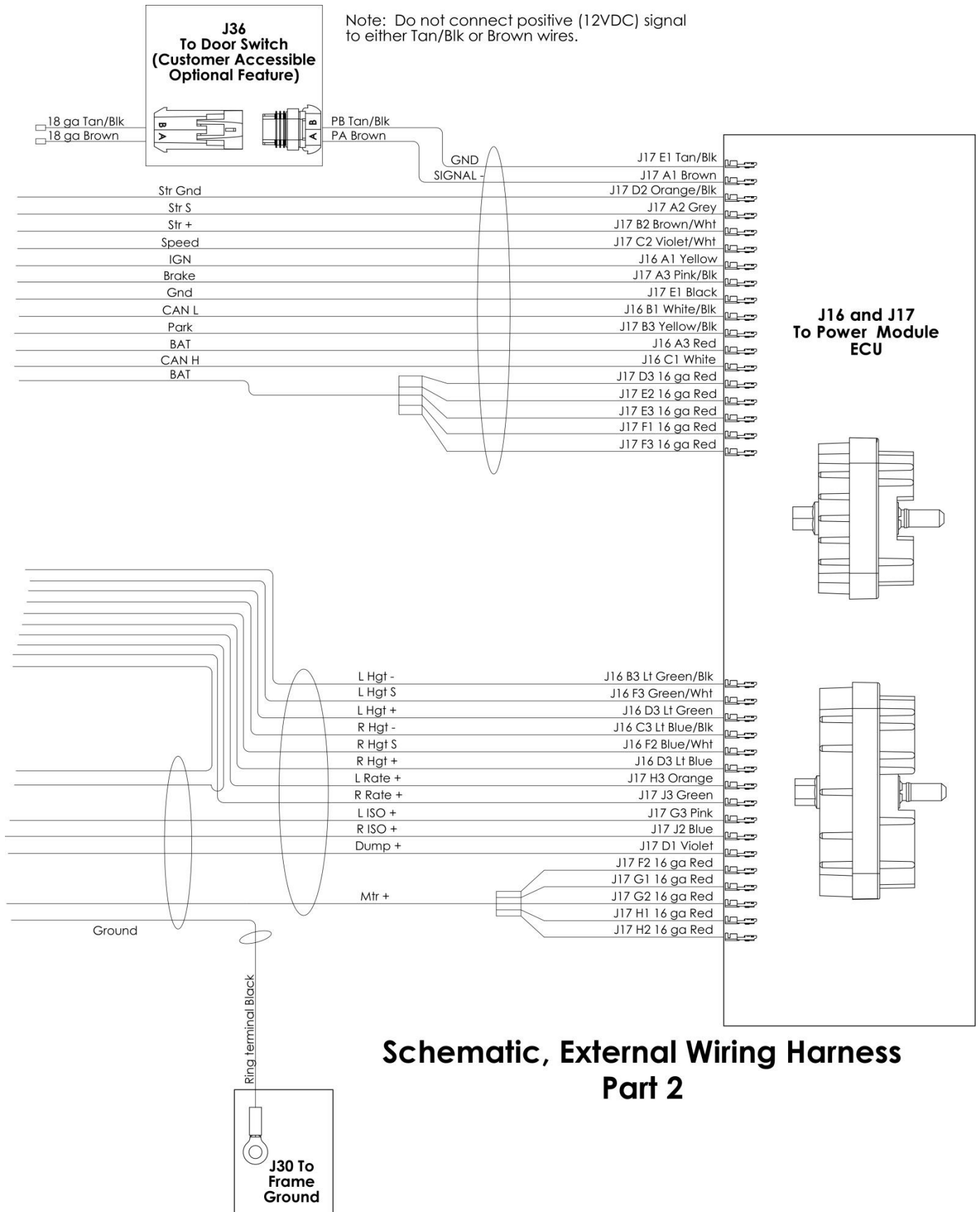



LiquidSpring™ LLC

4899 E 400 S
Lafayette, IN 47905

Phone: 765-474-7816

Fax: 765-474-7826

Web: www.liquidspring.com

Information contained in this publication is subject to change without notice or liability. LiquidSpring LLC reserves the right to revise the information presented or discontinue the production of parts described at any time.



CLASS[®] Product Limited Warranty

LIQUIDSPRING™ LLC
4899 E 400 S
LAFAYETTE, IN 47905
PH: 765-474-7816, FAX: 765-474-7826
WWW.LIQUIDSPRING.COM

Warranty Conditions

LiquidSpring LLC warrants that all **CLASS[®]** products shall be free of defects in material and workmanship provided the product has been properly assembled, installed by a designated/qualified installer, properly maintained, serviced, and used normally for the given application and within the rated capacities. The end user is responsible for operating, inspecting, and maintaining the product according to applicable product and vehicle owner's manuals and for instructing all operators and maintenance personnel on proper use and maintenance.

Coverage

The starting date for warranty coverage will be the earlier date of the date purchased by the first end user or when the vehicle is put into service and ends when the time period is reached in the warranty coverage period below. Proof of such date is the responsibility of the first end user. If the starting date cannot be satisfactorily determined, then the date of product manufacture based on the product serial number shall be used as the effective starting date.

Main Structural Components – 48 Months or 100,000 miles whichever occurs first.

Major structural components are defined as frame hangers, control arms, axle clamp group, transverse torque arm, axle and frame mounts, and secondary volumes. All wear items such as bushings and strut seals are excluded.

Other Components – 36 Months or 50,000 miles whichever occurs first.

Other components include all power module components, electrical components, wire harnesses, valves, hydraulic lines, and other wear items such as bushings and strut seals.

Labor – 12 Months

Estimated labor time and cost must be pre-approved prior to conducting warranty repair work for reimbursement consideration.

Claims

1. Review warranty conditions and coverage to determine if component is warrantable.
2. Locate product serial number, warranty starting date (see Coverage above), vehicle manufacturer, mileage, and VIN.
3. Contact LiquidSpring LLC to address claim.

Components must be returned to LiquidSpring LLC **Prepaid** and identified with a LiquidSpring LLC issued Returned Goods Authorization Number (RGA#) in order to qualify for reimbursement by LiquidSpring LLC. LiquidSpring LLC must authorize all warranty repairs at a cost determined and approved by LiquidSpring LLC **before any repairs are started**.

Warranty Contact: (765) 474-7816 (Option #1)
Service@liquidspring.com

Limitations and Exclusions

The liability of LiquidSpring LLC under this limited warranty is solely limited to the repair or replacement of defective material and workmanship by an authorized party. LiquidSpring LLC shall not be liable for use of non-LiquidSpring LLC components or for repairs performed by unauthorized parties. This warranty does not include any expense of or related to transportation of parts outside the Continental United States or compensation for inconvenience or loss of use while the product is being repaired. LiquidSpring LLC shall not be liable for any expense, loss, or damage (direct, incidental, consequential or exemplary – including, but not limited to towing expenses, travel expenses, vehicle rental, downtime expenses, incidental charges or any other losses arising in connection with the sale, use or inability to use the product) resulting from the warranty-covered component found to be defective.

No expressed warranty is given by LiquidSpring LLC with respect to its product except as specifically set forth herein. Any warranty implied by law, including any warranty of merchantability or fitness for particular purpose, is limited to the expressed warranty term provided in the warranty coverage. The expressed warranty does not apply in the event of: use of non-LiquidSpring LLC replacement components; improper installation, maintenance or repair; misuse, negligence, or abuse including but not limited to overloading, unauthorized alterations or modifications.



CLASS[®] Product Limited Warranty

LIQUIDSPRING™ LLC
4899 E 400 S
LAFAYETTE, IN 47905
PH: 765-474-7816, FAX: 765-474-7826
WWW.LIQUIDSPRING.COM

Warranty Labor Coverage

COMPONENT	ALLOWABLE LABOR HOURS (*)
Strut (each)	0.75
Wiring Harness (Rear Main)	3.00
Power Module	1.00
Pressure Relief Valve/Isolation Valve	0.50**
ECU (External)	0.50
Hose Replacement (each)	0.75
Height Sensor	0.50
Steering Sensor	0.75
Rate Valve	0.50
Track Rod	1.50
One Control Arm	1.50
Pair of Control Arms	2.00
12V Motor	1.00
General Diagnostics	Contact Customer Service

(FOR ANY COMPONENT(S) NOT LISTED ABOVE, THE ALLOWABLE LABOR HOURS MUST BE APPROVED BY LIQUIDSPRING LLC. PRIOR TO THE WORK BEING PREFORMED.)

*LABOR HOURS BASED ON \$85.00 PER HOUR.

*LABOR FOR DIAGNOSIS WILL NOT BE COVERED WITHOUT PRIOR CONSENT FROM LIQUIDSPRING LLC.

**0.50hr. FOR FIRST VALVE REMOVAL 0.25hr. FOR EACH ADDITIONAL

Obtaining Warranty Parts

1. Obtain **LiquidSpring LLC** suspension serial number
(Located on driver's side front hanger see Operator's Manual for details)
2. Obtain mileage of suspension
3. Obtain In-service date of suspension
4. Give a detailed description of the problem

Contact LiquidSpring LLC

Customer Service Dept. -- Phone: 765-474-7816 (Option #1) Email: Service@liquidspring.com