

International CV & Chevrolet Silverado 4500HD/5500HD/6500HD

Drive Axle Rear Suspensions

Air Ride Conversion

Model: DS135NCV2-A (10K-13.5K GAWR)

DS155NCV2-A (15K-15.5K GAWR)

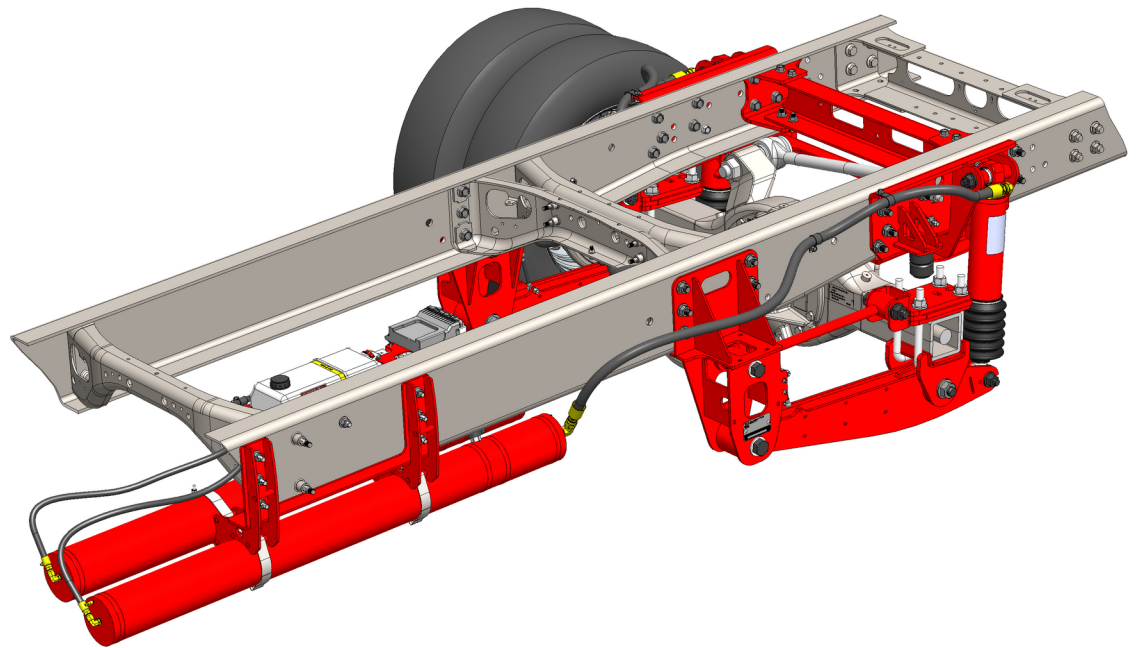

- Non-torque reactive design optimized with CLASS®
- Maintains proper driveline geometry through full range of torque inputs reducing driveline noise, vibration, and fatigue
- Variable stiffness and damping adjusted automatically and instantaneously based on road conditions without driver intervention
- Does not require modification to exhaust
- Compact package space claim
- 13,500 lbs - 15,500 lbs GAWR



Compressible Liquid Adaptive Suspension System

CLASS®

International CV / GM Silverado 4500HD/5500HD/6500HD Air Ride Conversion, 13,500 lbs - 15,500 lbs GAWR

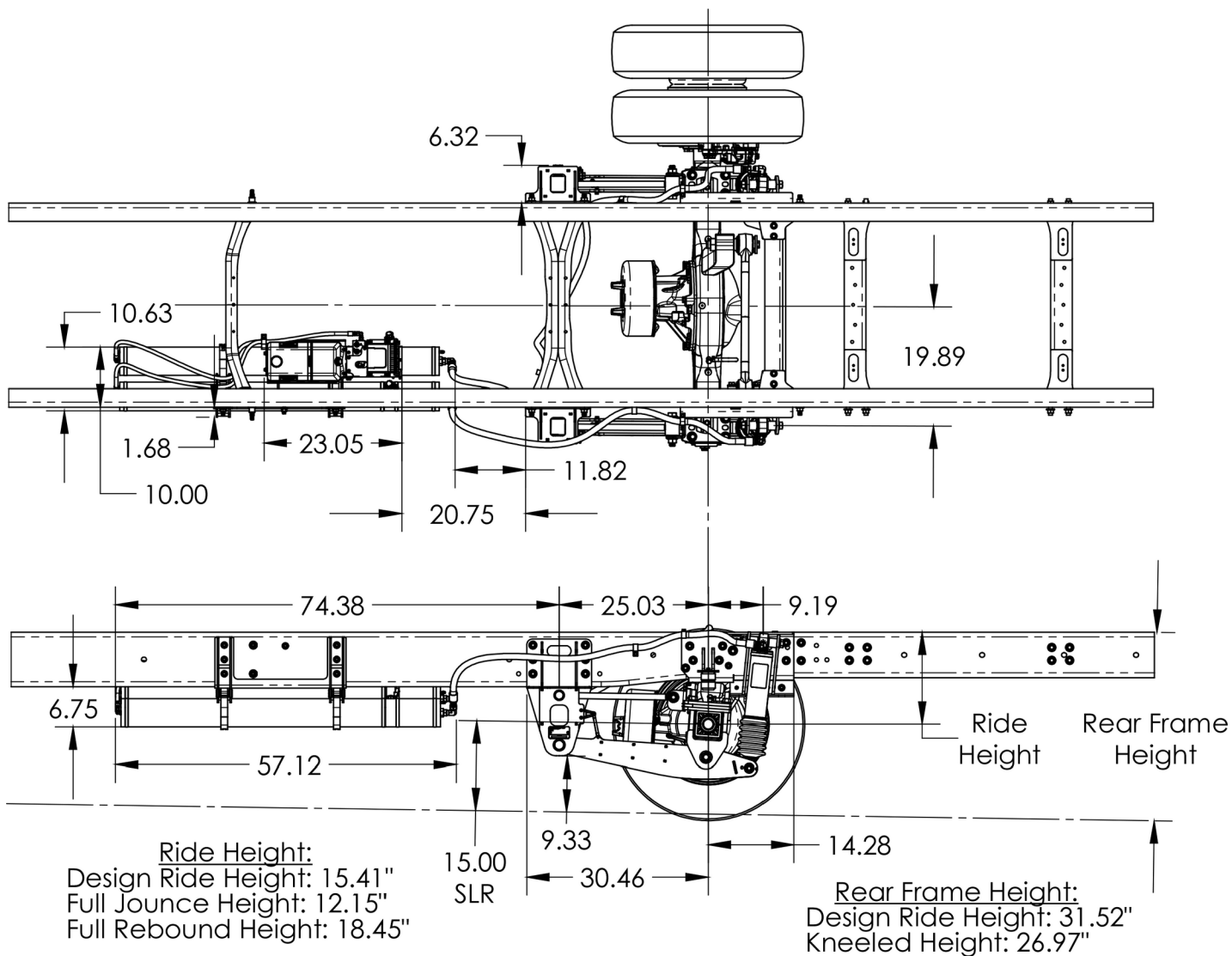

LiquidSpring™ LLC
4899 E 400 S
Lafayette, IN 47905

Phone: 765-474-7816
Fax: 765-474-7826

Web: www.liquidspring.com